

*By* CARPEL<sup>®</sup>   
srl

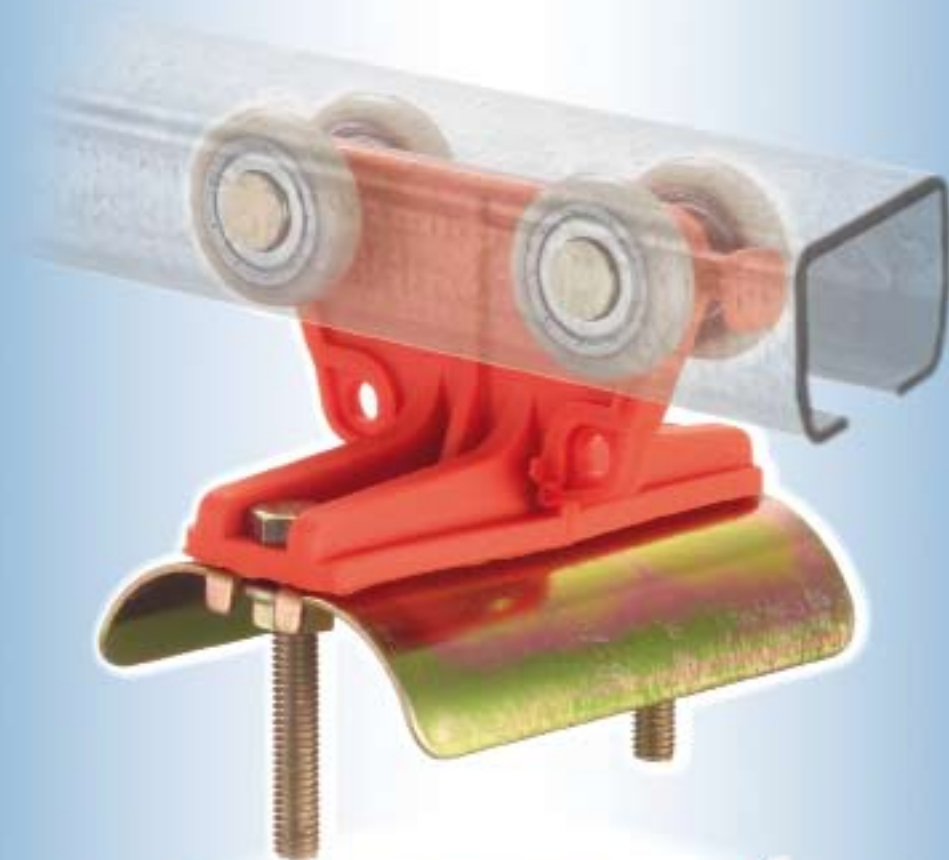

## LINEA PORTACAVI "TIPO EUROPEO" CABLE CARRYING LINE "EUROPEAN" TYPE

La linea portacavi tipo EUROPEO è un sistema pratico, efficiente e sicuro per la distribuzione dell'energia, sia essa elettrica, pneumatica o altro, per apparecchi mobili quali gru, carri ponti etc.

In questo catalogo troverete sicuramente la soluzione più adatta al vostro problema potendo scegliere tra più linee di carrelli portacavi tutti normalizzati per scorrere in maniera sicura, efficiente e duratura all'interno della canalina di nostra produzione. Qualunque sia la scelta da voi operata, sarà una scelta di qualità e sicurezza in quanto su tutte le linee troverete apposto il marchio "CE" a garanzia che i nostri prodotti rispondono ai requisiti dettati dalla Direttiva Macchine 89/932 CEE e successivi emendamenti.

*The cable carrying line "EUROPEAN" type is a handy, efficient and safe system for electrical, pneumatic and other energy distribution to mobile equipment such as cranes, overhead traveling cranes, etc.*

*This catalogue includes various cable carrying lines; among them you will surely find the most suitable to your requirements. You may choose among several lines of cable carrying trolleys, all of them being standardized for assuring a safe, efficient and lasting sliding operation inside our cable raceway. Regardless of your choice, it will assure you quality and safety; all our lines have been labelled with the "CE" mark, to guarantee that our products meet the 89/932/EEC Machinery Directive and further amendments.*



Ci riserviamo la facoltà di apportare, senza alcun preavviso, modifiche costruttive al fine di migliorare le qualità tecniche, funzionali ed estetiche del prodotto.

*We reserve the right to make modifications in order to improve the technical, functional and aesthetical qualities of our products without any prior notice.*



AZIENDA CON SISTEMA QUALITÀ  
CERTIFICATO DA DNV  
=UNI EN ISO 9001/2000=

**Canalina Portacavo**  
**Cable carrying raceway**

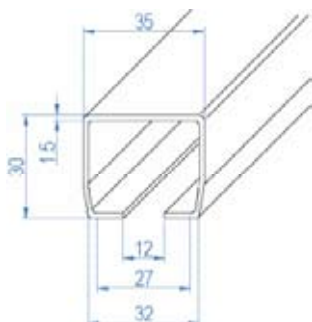
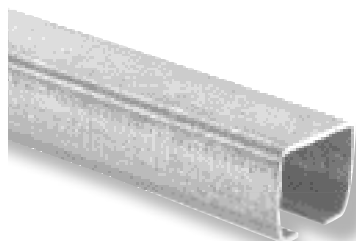

Materiale/Material	Acciaio zincato/Galvanized Steel
Spessore/Thickness	1,5 mm
Momento d'inerzia/Moment of inertia	1,9 cm <sup>4</sup>
Momento resistente/Resisting moment	1,1 cm <sup>3</sup>
Peso/Weight	1,19 kg/m
Distanza sospensioni/Suspension distance	1,5 m
Portata/Capacity	30 kg ogni/every 1,5 m

<b>Articolo/Item</b>	<b>1</b>
Codice barre/Bar code 3	CAN 1 EUR 3
Codice barre/Bar code 4	CAN 1 EUR 4
Codice barre/Bar code 5	CAN 1 EUR 5
Codice barre/Bar code 6	CAN 1 EUR 6

**Testata semplice in nylon**  
**Nylon simple head**

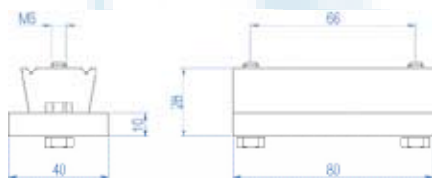

Materiale/Material	Corpo in nylon/Nylon body
	Minuteria in acciaio zincato/Small parts in galvanized steel
Peso/Weight	65 g

<b>Articolo/Item</b>	<b>5</b>
Codice/Code	TS 1 SEMPN

**Testata semplice in acciaio**  
**Steel simple head**

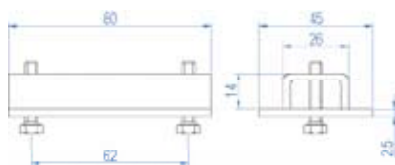
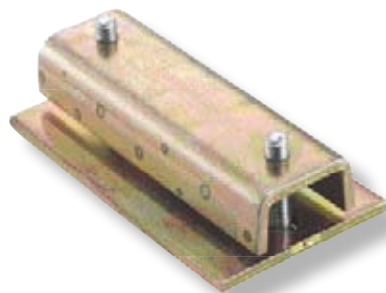

Materiale/Material	Acciaio zincato/Galvanized Steel
Peso/Weight	175 g

<b>Articolo/Item</b>	<b>5</b>
Codice/Code	TS 1 SEMPA

**LINEA PORTACAVI "TIPO EUROPEO"**  
**CABLE CARRYING LINE "EUROPEAN TYPE"**



**Sospensione con fissaggio laterale**  
**Suspension with side fixing**

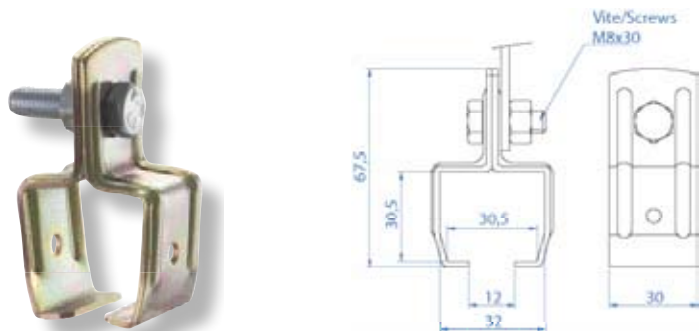

Materiale/Material	Acciaio zincato/Galvanized Steel	
	con viti with screws	senza viti without screws
Peso/Weight	100 g	80 g
Portata/Capacity	30 kg	30 kg

<b>Articolo/Item</b>	<b>3</b>	<b>4</b>
Codice/Code	SOS 1 FLCV	SOS 1 FLSV

**Sospensione con fissaggio a parete**  
**Suspension with wall fixing**

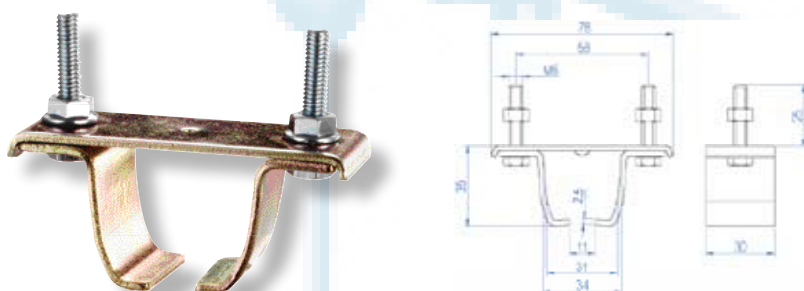

Materiale/Material	Acciaio zincato/Galvanized Steel	
	con viti with screws	senza viti without screws
Peso/Weight	125 g	100 g
Portata/Capacity	45 kg	45 kg

<b>Articolo/Item</b>	<b>4+4</b>	<b>4+4</b>
Codice/Code	SOS 1 PACV	SOS 1 PASV

**Sospensione a parete con fissaggio di tipo composto**  
**Wall suspension with built-up fixing system**

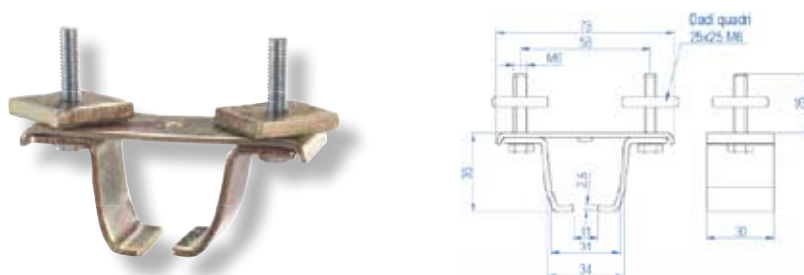

Materiale/Material	Acciaio zincato/Galvanized Steel	
Peso/Weight	150 g	
Portata/Capacity	45 kg	

<b>Articolo/Item</b>	<b>4+4/C</b>
Codice/Code	SOS 1 PATC

**Giunto doppio in acciaio**  
**Double steel joint**

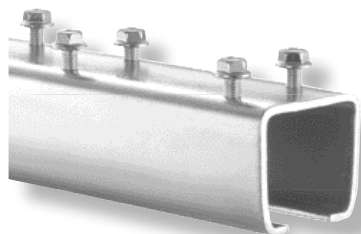

Materiale/ Material	Acciaio zincato/ Galvanized Steel
Peso/ Weight	485 g

<b>Articolo/ Item</b>	<b>2 bis</b>
Codice/ Code	GIU 1 FD

**Giunto semplice in acciaio**  
**Simple steel joint**

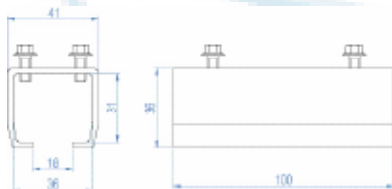
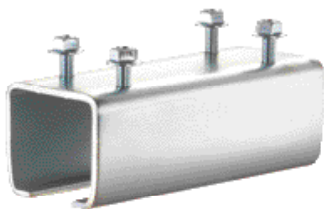

Materiale/ Material	Acciaio zincato/ Galvanized Steel
Peso/ Weight	235 g

<b>Articolo/ Item</b>	<b>2</b>
Codice/ Code	GIU 1 FS

**Giunto semplice in nylon**  
**Simple nylon joint**

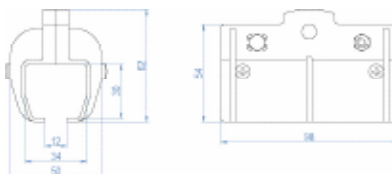

Materiale/ Material	Nylon
Peso/ Weight	90 g

<b>Articolo/ Item</b>	<b>2</b>
Codice/ Code	GIU 1 NY

## LINEA PORTACAVI "TIPO EUROPEO" CABLE CARRYING LINE "EUROPEAN TYPE"



### Testata con sella Head with saddle

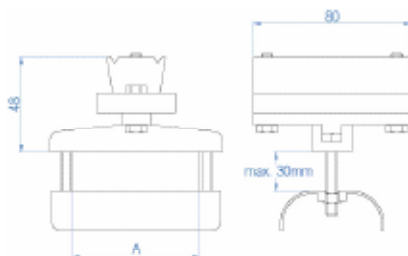

Materiale/Material	Corpo in nylon/Nylon body
	Acciaio zincato/Galvanized steel
Portata/Capacity	25 kg

Sella/Saddle	Peso/Weight	Codice/Code	Articolo/Item
A= 35 mm	155 g	TSN1P35	<b>6</b>
A= 50 mm	165 g	TSN1P50	<b>7</b>
A= 65 mm	175 g	TSN1P65	<b>8</b>

### Carrello portacavi Cable carrying trolley

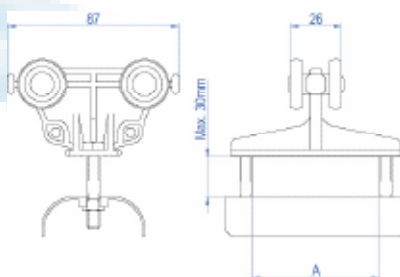

Materiale/Material	Corpo in nylon/Nylon body
	Acciaio zincato/Galvanized steel

Ruote Nylon/Nylon Wheels	Ø 25 mm
Portata/Capacity	15 kg

Sella/Saddle	Peso/Weight	Codice/Code	Articolo/Item
A= 35 mm	115 g	CRN1P35N	<b>9</b>
A= 50 mm	125 g	CRN1P50N	<b>10</b>
A= 65 mm	145 g	CRN1P65N	<b>11</b>

Cuscinetti rivestiti in nylon/Nylon coated bearing	Ø 25 mm
Portata/Capacity	20 kg

Sella/Saddle	Peso/Weight	Codice/Code	Articolo/Item
A= 35 mm	135 g	CRN1P35C	<b>12</b>
A= 50 mm	145 g	CRN1P50C	<b>13</b>
A= 65 mm	165 g	CRN1P65C	<b>14</b>

### Traino Trailer

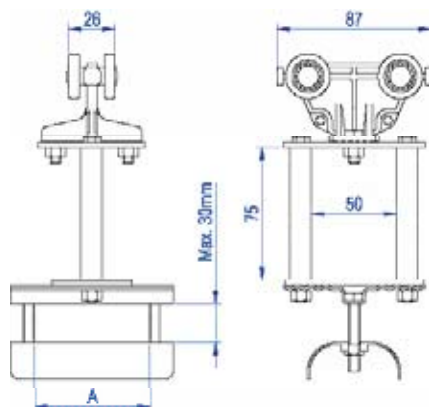

Materiale/Material	Corpo in nylon/Nylon body
	Acciaio zincato/Galvanized steel

Ruote Nylon/Nylon Wheels	Ø 25 mm
Portata/Capacity	10 kg

Sella/Saddle	Peso/Weight	Codice/Code	Articolo/Item
A= 35 mm	130 g	TRN1P35N	<b>15</b>
A= 50 mm	140 g	TRN1P50N	<b>16</b>
A= 65 mm	160 g	TRN1P65N	<b>17</b>

Cuscinetti rivestiti in nylon/Nylon coated bearing	Ø 25 mm
Portata/Capacity	15 kg

Sella/Saddle	Peso/Weight	Codice/Code	Articolo/Item
A= 35 mm	165 g	TRN1P35C	<b>18</b>
A= 50 mm	170 g	TRN1P50C	<b>19</b>
A= 65 mm	190 g	TRN1P65C	<b>20</b>

**LINEA PORTACAVI "TIPO EUROPEO"**  
**CABLE CARRYING LINE "EUROPEAN TYPE"**



**Testata con sella**  
**Head with saddle**

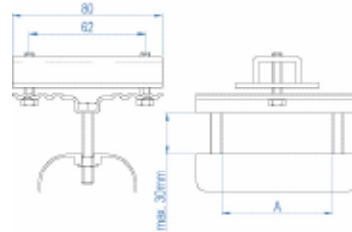
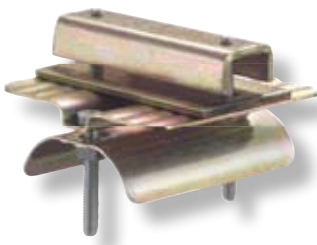

Materiale/Material	Acciaio zincato/Galvanized Steel
Portata/Capacity	35 kg

Sella/Saddle	Peso/Weight	Codice/Code	Articolo/Item
A= 25 mm	265 g	TSA 1 P25	<b>60</b>
A= 35 mm	285 g	TSA 1 P35	<b>61</b>
A= 55 mm	320 g	TSA 1 P55	<b>62</b>
A= 65 mm	340 g	TSA 1 P65	<b>63</b>
A= 80 mm	365 g	TSA 1 P80	<b>64</b>
A= 100 mm	400 g	TSA 1 P10	<b>65</b>

**Carrello portacavi**  
**Cable carrying trolley**

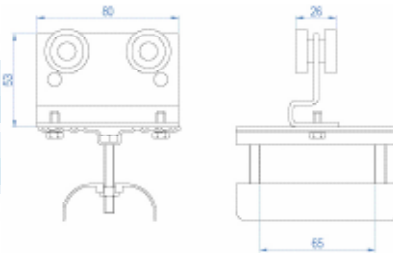

Materiale/Material	Acciaio zincato/Galvanized Steel
Ruote/Wheels	Cuscinetti acciaio/Steel coated bearings Ø 25 mm
Portata/Capacity	30 kg

Sella/Saddle	Peso/Weight	Codice/Code	Articolo/Item
A= 25 mm	310 g	CRA 1 P25C	<b>66</b>
A= 35 mm	330 g	CRA 1 P35C	<b>67</b>
A= 55 mm	365 g	CRA 1 P55C	<b>68</b>
A= 65 mm	385 g	CRA 1 P65C	<b>69</b>
A= 80 mm	410 g	CRA 1 P80C	<b>70</b>
A= 100 mm	445 g	CRA 1 P10C	<b>71</b>

**Traino**  
**Trailer**

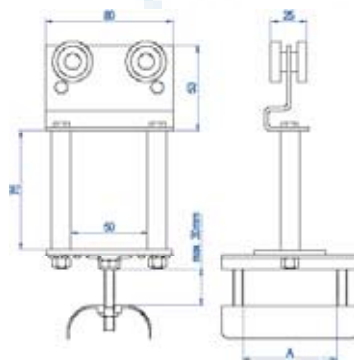

Materiale/Material	Acciaio zincato/Galvanized Steel
Ruote/Wheels	Cuscinetti acciaio/Steel coated bearings Ø 25 mm
Portata/Capacity	25 kg

Sella/Saddle	Peso/Weight	Codice/Code	Articolo/Item
A= 25 mm	485 g	TRA 1 P25C	<b>72</b>
A= 35 mm	505 g	TRA 1 P35C	<b>73</b>
A= 55 mm	540 g	TRA 1 P55C	<b>74</b>
A= 65 mm	560 g	TRA 1 P65C	<b>75</b>
A= 80 mm	585 g	TRA 1 P80C	<b>76</b>
A= 100 mm	620 g	TRA 1 P10C	<b>77</b>

**Carrello portacavi - due pezzi**  
**Two-piece cable carrying trolley**

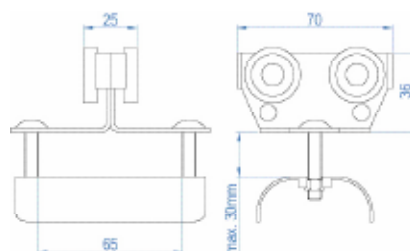
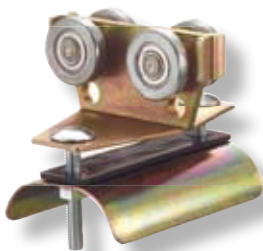

Materiale/Material	Acciaio zincato/Galvanized Steel
Ruote/Wheels	Cuscinetti acciaio/Steel coated bearings Ø 25 mm
Portata/Capacity	20 kg

Sella/Saddle	Peso/Weight	Codice/Code	Articolo/Item
A= 65 mm	260 g	CRD 1 P65C	<b>69 bis</b>

**Testata sella girevole**  
Head with slewing saddle

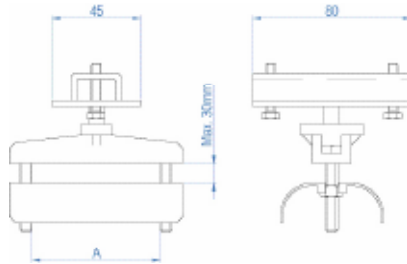
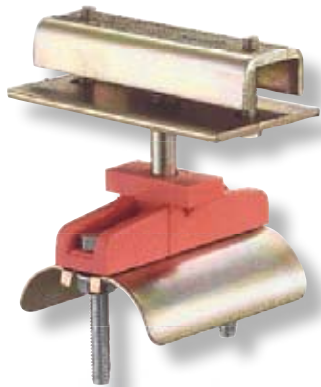

Materiale/Material	Acciaio zincato/Galvanized Steel
Portata/Capacity	25 kg

Sella/Saddle	Peso/Weight	Codice/Code	Articolo/Item
A= 35 mm	210 g	TSA1P35SG	<b>61-G</b>
A= 50 mm	275 g	TSA1P55SG	<b>62-G</b>
A= 65 mm	295 g	TSA1P65SG	<b>63-G</b>

**Carrello sella girevole**  
Trolley with slewing saddle

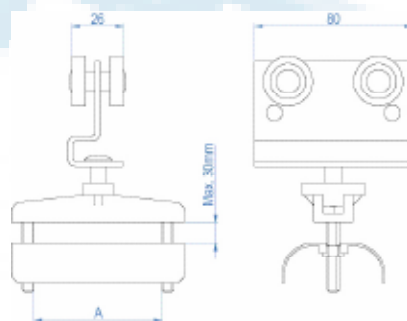

Materiale/Material	Acciaio zincato/Galvanized Steel
Ruote/Wheels	Cuscinetti acciaio/Steel coated bearings Ø 25 mm
Portata/Capacity	20 kg

Sella/Saddle	Peso/Weight	Codice/Code	Articolo/Item
A= 35 mm	385 g	CRA1P35SG	<b>67-G</b>
A= 50 mm	320 g	CRA1P55SG	<b>68-G</b>
A= 65 mm	340 g	CRA1P65SG	<b>69-G</b>

**Traino sella girevole**  
Trailer with slewing saddle

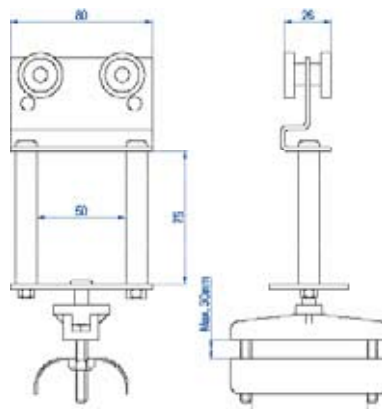

Materiale/Material	Acciaio zincato/Galvanized Steel
Ruote/Wheels	Cuscinetti acciaio/Steel coated bearings Ø 25 mm
Portata/Capacity	15 kg

Sella/Saddle	Peso/Weight	Codice/Code	Articolo/Item
A= 35 mm	450 g	TRA1P35SG	<b>73-G</b>
A= 50 mm	495 g	TRA1P55SG	<b>74-G</b>
A= 65 mm	515 g	TRA1P65SG	<b>75-G</b>



**Testata con morsetto**  
**Head with clamp**

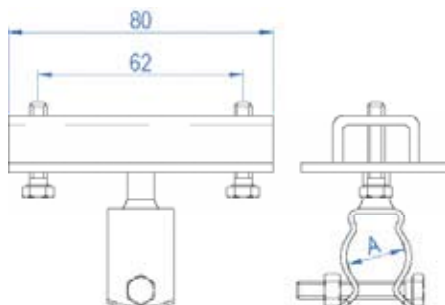
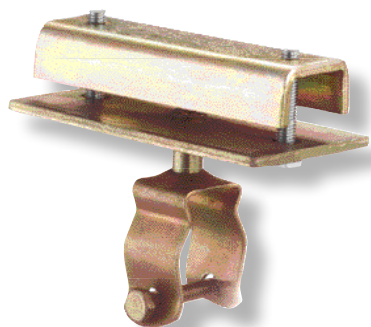

Materiale/Material	Acciaio zincato/Galvanized Steel
Portata/Capacity	30 kg
A (Ø max cavo/Cable max)	22 mm
Peso/Weight	205 g

<b>Articolo/Item</b>	<b>42</b>
Codice/Code	TSN 1 M22

**Carrello con morsetto**  
**Trolley with clamp**

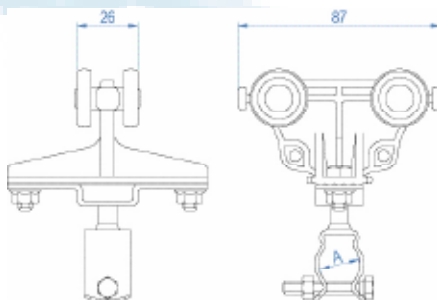

Materiale/Material	Corpo in nylon/Nylon body	
Minuterie in acciaio zincato/Small parts in galvanized steel		
Ruote/Wheels	Nylon Ø 25 mm	
Cuscinetti rivestiti nylon/Nylon coated bearings Ø 25 mm		
Portata/Capacity	20 kg	
A (Ø max cavo/Cable max)	22 mm	

	Ruote nylon	Ruote cuscinetto
	Nylon wheels	Wheels with bearing
Peso/Weight	130 g	150 g

<b>Articolo/Item</b>	<b>45</b>	<b>46</b>
Codice/Code	CRN 1 M22N	CRN 1 M22C

**Traino con morsetto**  
**Trailer with clamp**

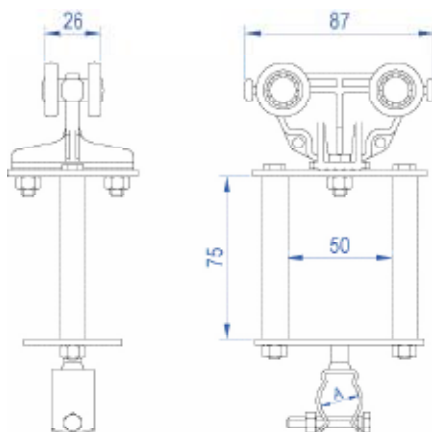

Materiale/Material	Corpo in nylon/Nylon body	
Minuterie in acciaio zincato/Small parts in galvanized steel		
Ruote/Wheels	Nylon Ø 25 mm	
Cuscinetti rivestiti nylon/Nylon coated bearings Ø 25 mm		
A (Ø max cavo/Cable max)	22 mm	

	Ruote nylon	Ruote cuscinetto
	Nylon wheels	Wheels with bearing
Peso/Weight	390 g	415 g
Portata/Capacity	15 kg	20 kg

<b>Articolo/Item</b>	<b>47</b>	<b>48</b>
Codice/Code	TRN 1 M22N	TRN 1 M22C

**Connettore per cavo piatto - presa tipo CARPEL**  
**Connector for flat cable - socket type CARPEL**

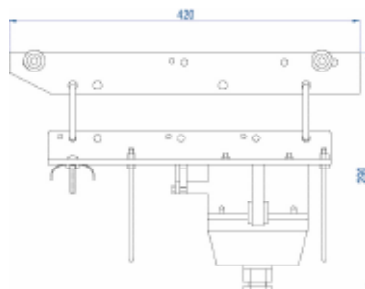
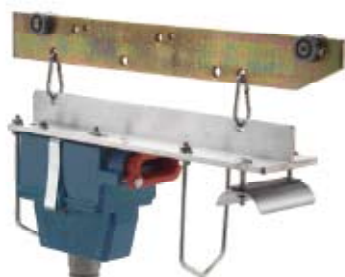

Materiale/Material	Piastra in alluminio/Alluminium plate		
	Presa in nylon/Nylon socket		
	Stecca in acciaio zincato/Galvanized steel slat		
	Minuteria in acciaio zincato/Small parts in galvanized steel		
Ruote/Wheels	Cuscinetti acciaio/Steel coated bearings Ø 25 mm		
Portata/Capacity	35 kg		
Peso/Weight	2900 g		

Articolo/Item	015	030	040
Codice/Code	CON 1 P10	CON 1 P16	CON 1 P24
	10 Poli/Pole	16 Poli/Pole	24 Poli/Pole

**Connettore per cavo piatto - presa tipo STANDARD**  
**Connector for flat cable - socket type STANDARD**

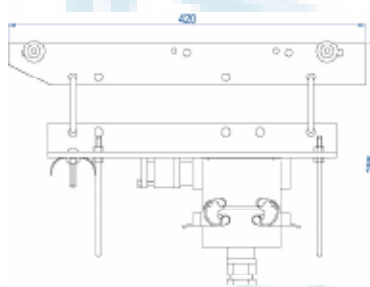

Materiale/Material	Piastra in alluminio/Alluminium plate			
	Presa in alluminio/Alluminium socket			
	Stecca in acciaio zincato/Galvanized steel slat			
	Minuteria in acciaio zincato/Small parts in galvanized steel			
Ruote/Wheels	Cuscinetti acciaio/Steel coated bearings Ø 25 mm			
Portata/Capacity	35 kg			
Peso/Weight	2660 g			

Articolo/Item	026	027	028	029
Codice/Code	CON 1 P10I	CON 1 P16I	CON 1 P24I	CON 1 P32I
	10 Poli/Pole	16 Poli/Pole	24 Poli/Pole	32 Poli/Pole

**Connettore per cavo tondo - presa tipo STANDARD**  
**Connector for round cable - socket type STANDARD**

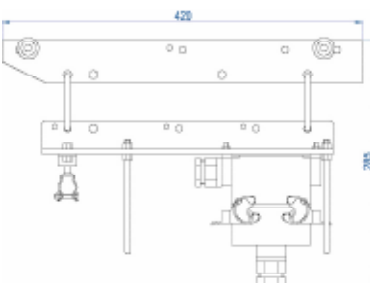

Materiale/Material	Piastra in alluminio/Alluminium plate			
	Presa in alluminio/Alluminium socket			
	Stecca in acciaio zincato/Galvanized steel slat			
	Minuteria in acciaio zincato/Small parts in galvanized steel			
Ruote/Wheels	Cuscinetti acciaio/Steel coated bearings Ø 25 mm			
Portata/Capacity	35 kg			
Peso/Weight	2885 g			

Articolo/Item	005	010	020	025
Codice/Code	CON 1 T10	CON 1 T16	CON 1 T24	CON 1 T32
	10 Poli/Pole	16 Poli/Pole	24 Poli/Pole	32 Poli/Pole

**Traino speciale**  
**Special trailer**

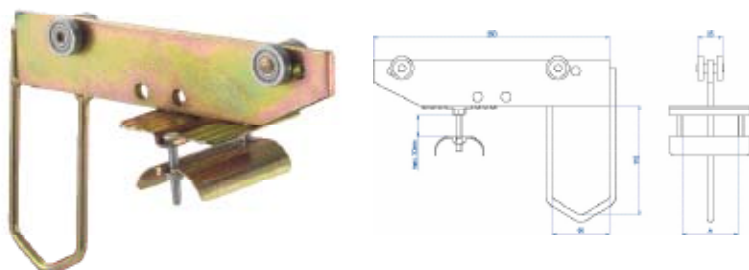

Materiale/Material	Acciaio zincato/Galvanized Steel
Ruote/Wheels	Cuscinetti acciaio/Steel coated bearings Ø 25 mm
Portata/Capacity	30 kg

Sella/Saddle	Peso/Weight	Codice/Code	Articolo/Item
A= 25 mm	270 g	TRA 1 S25C	<b>001</b>
A= 35 mm	330 g	TRA 1 S35C	<b>002</b>
A= 55 mm	345 g	TRA 1 S55C	<b>003</b>
A= 65 mm	370 g	TRA 1 S65C	<b>004</b>
A= 80 mm	395 g	TRA 1 S80C	<b>006</b>
A= 100 mm	430 g	TRA 1 S10C	<b>007</b>

**Traino a stecca**  
**Slat trailer**

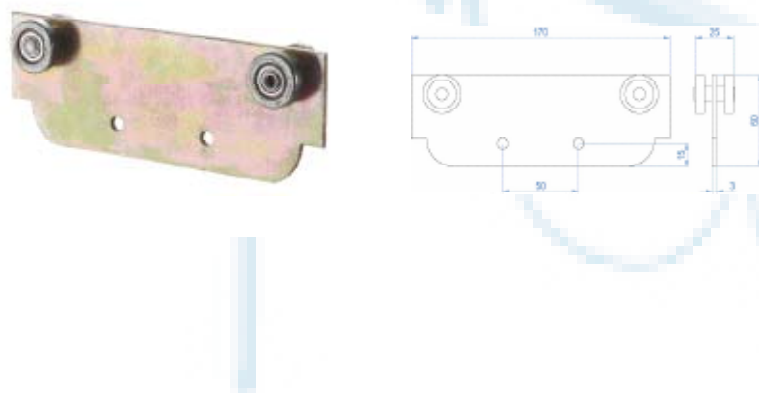

Materiale/Material	Acciaio zincato/Galvanized Steel
Ruote/Wheel	Cuscinetti acciaio/Steel coated bearings Ø 25 mm
Portata/Capacity	30 kg
Peso/Weight	270 g

<b>Articolo/Item</b>	<b>170</b>
Codice/Code	TRA 1 STEC

**Griffa portacavi**  
**Cable carrying claw**

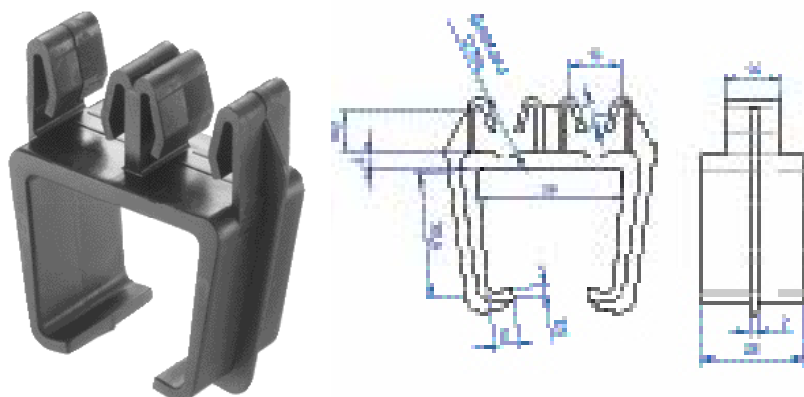

Materiale/Material	Nylon
Peso/Weight	15 g

<b>Articolo/Item</b>	<b>4201</b>
Codice/Code	GRIFFA/EUR



**ISTRUZIONI DI MONTAGGIO - linea con traino -**  
**ASSEMBLY INSTRUCTIONS - line with trailer -**

- 1- Posizionare le sospensioni nelle proprie sedi (pareti o mensole); in questa fase di montaggio non bisogna stringere eccessivamente le viti delle sospensioni, in modo da permettere l'inserimento delle barre di canalina ed il loro eventuale posizionamento.
- 2- Inserire le barre di canalina nelle sospensioni; verificare la presenza di un numero adeguato di sospensioni su tutta la linea.  
In questa fase è necessario prestare particolare attenzione allo “spigolo vivo” del taglio della canalina: tale spigolo è necessario per un corretto allineamento delle parti di canalina da unire e per far scorrere correttamente il carrello all'interno.
- 3- Applicare i giunti alle estremità delle barre, quindi serrare le viti senza deformare la canalina. Le estremità delle canaline devono essere adiacenti e ben allineate (la conformazione del giunto impedisce il non allineamento delle canaline) onde evitare che il carrello durante la corsa urti contro l'estremità della canalina e che, con il passare del tempo, sia pregiudicato il buon funzionamento del carrello stesso.
- 4- Serrare tutte le viti delle sospensioni verificando nel medesimo tempo il bloccaggio dell'intera linea.
- 5- Verificare l'allineamento dell'intera linea.
- 6- Inserire la prima testata (senza sella) e fissarla all'estremità opposta a quella in cui la linea si allaccerà all'alimentazione.
- 7- Inserire il traino nella canalina nell'estremità senza testata.
- 8- Di seguito, nello stesso modo, inserire tutti i carrelli che sosterranno il cavo di alimentazione
- 9- Posizionare la testata rimanente (con sella) e fissarla in modo da chiudere la linea. La chiusura della linea impedisce la fuoriuscita del traino e dei carrelli.
- 10- Inserire il cavo conduttore nel carrello, tra sella e controsella, partendo dalla testata con la sella sino ad arrivare al traino.
- 11- Stringere le viti del carrello, fissando il cavo tra sella e controsella, avendo cura di verificare che non sia presente alcun movimento di scorrimento del cavo nel carrello.
- 12- Lasciare tra carrello e carrello una quantità di cavo pari all'ansa desiderata.

*1- Place the suspensions into their seats (walls or brackets), without overtightening the suspension screws so as to allow the raceway bars to be inserted and positioned, if necessary.*

*2- Insert the raceway bars into the suspensions; be sure that a proper number of suspensions are all over the line.*

*In this phase particular attention has to be paid to the “sharp edge” of the raceway cutting side: such an edge is required to properly align the raceway parts to be connected and for the trolley to properly slide inside.*

*3- Apply the joints to the bar ends, then tighten the screws without deforming the raceway. The raceway ends must be adjacent and well aligned (the joint configuration avoids the raceway misalignment) preventing the trolley to strike the raceway ends during its stroke and the trolley to properly work in the time.*

*4- Tighten all the suspension screws while checking that all the line is locked.*

*5- Verify that all the line is properly aligned.*

*6- Insert the first head (without the saddle), fixing it at the end opposite to that where the line will be connected to the feeding line.*

*7- Insert the trailer into the raceway at the headless end.*

*8- Insert now all the trolleys that will have to carry the feeding cable, proceeding the same way as above.*

*9- Position the remaining head (with the saddle) and fix it in such a way that the line is closed. The line closing prevents the trailer and the trolleys to come out.*

*10- Insert the conductor cable into the trolley, between the saddle and the countersaddle. Start inserting the saddle from the head until reaching the trailer.*

*11- Tighten the trolley screws fixing the cable between the saddle and the countersaddle, paying attention to as the cable into the trolley does not slide at all.*

*12- Leave a quantity of cable between each trolley equal to the required loop.*

## **ISTRUZIONI DI MONTAGGIO - linea con pulsantiera -** **ASSEMBLY INSTRUCTIONS - line with push-button panel -**

Nel caso si debba montare la linea di azionamento comandi, il procedimento è simile al precedente, avendo però l'accortezza di inserire al posto del traino (precedente punto 7) il connettore. Il montaggio del connettore avviene nel modo seguente.

- 1- Preparare il cavo piatto montato sulla linea, eliminando 3 cm circa di guaina esterna e 1 cm circa di guaina per ogni singolo cavetto interno.
  - 2- Far passare il cavo piatto tra la sella e la piastra del connettore.
  - 3- Aprire il connettore: se si tratta di connettore in nylon (nei colori: arancio, azzurro o giallo), fare leva sull'estremità della molla mediante un utensile (pinza o cacciavite); se si tratta di connettore metallico, premere le due leve esterne in modo da liberare l'aggancio. Rimuovere quindi il coperchio.
  - 4- Prendere i frutti all'interno del connettore e separarli, nel caso non lo fossero già.
  - 5- Far passare il cavo piatto attraverso il pressacavo posto sulla base del connettore.
  - 6- Connettere il cavo piatto della linea al frutto femmina (frutto senza i pioli di contatto esterni), inserendo i singoli cavetti nelle apposite sedi numerate e serrando le viti relative a ogni sede per bloccare il cavo. La sequenza di connessione dei cavi è a cura dell'installatore a seconda delle proprie esigenze.
  - 7- Inserire il frutto femmina nella base del connettore bloccandolo mediante le quattro viti poste agli angoli.
  - 8- Serrare le viti del pressacavo sulla base del connettore onde evitare l'ingresso di polvere o altro.
  - 9- Serrare le viti della sella lasciando abbondante il cavo tra la sella e il pressacavo.
  - 10- Far passare il cavo tondo della pulsantiera attraverso il pressacavo del coperchio del connettore, dopo aver separato, per circa 40-50 cm, il cavo stesso dai cavetti metallici laterali.
  - 11- Eliminare le guaine come indicato per il cavo piatto e connettere il cavo tondo al frutto maschio (quello con i pioli di contatto esterni), avendo cura di seguire le istruzioni date per il frutto femmina e seguendo lo stesso ordine di connessione.
  - 12- Fissare il frutto maschio al coperchio del connettore utilizzando le quattro viti poste agli angoli dello stesso.
  - 13- Applicare il coperchio del connettore alla base, avendo cura di far coincidere i due frutti, quindi serrarlo utilizzando le leve, per i connettori di tipo STANDARD, o la molla, per connettore tipo CARPEL in nylon.
  - 14- Far compiere al cavo tondo un giro completo, quindi fissare un cavetto laterale a ciascun tirante della piastra.
  - 15- Per mezzo di una fascetta fissare i cavetti laterali metallici al cavo tondo nel punto in cui questi si incontrano, evitando così che durante l'utilizzo i cavetti laterali si separino ulteriormente dal cavo tondo.
  - 16- Fissare ad un cavetto laterale il cavo tondo per mezzo di una fascetta in un punto del giro a vuoto del cavo.
- Questa operazione, unita a lasciare un giro a vuoto di cavo, è necessaria per evitare che durante l'utilizzo il tiro sul cavo vada a ripercuotersi sui contatti all'interno del connettore, anziché distribuirsi sui cavetti metallici.
- 17- Serrare il pressacavo posto sul coperchio del connettore girando la vite del pressacavo stesso al fine di evitare l'ingresso di polvere o altro.

*Should the drive controls line be installed, the process is similar to the previous one but the connector must be inserted instead of the trailer (see previous point 7). Install the connector as follows:*

- 1- *Mount the flat cable on the line and remove approx. 3 cm of external sheath and approx. 1 cm of sheath for each inside wire.*
- 2- *Run the flat cable between the saddle and the connector plate.*
- 3- *Open the connector: should it be a nylon one (orange, light blue or yellow coloured) lever, by a pro per tool (pliers or screwdriver), the spring end. Should it be a metal connector, press the two external levers for releasing the coupling. Remove the cover.*
- 4- *Take the contact blocks inside the connector. Separate them, if necessary.*
- 5- *Run the flat cable through the cable gland placed on the connector base.*
- 6- *Connect the line flat cable to the female contact block (contact block without the external contact pins) by inserting the single wires into the proper numbered seats. Fix the cable by tightening the relevant screws to each seat. The cable connection sequence is provided by the installer according to his own requirements.*
- 7- *Insert the female contact block into the connector base and lock it by the four screws placed at the edges.*
- 8- *Tighten the cable gland screws to the connector base, thus preventing any dust or other foreign matters to enter.*
- 9- *Tighten the saddle screws paying attention to leave a big quantity of cable between the saddle and the cable gland.*
- 10- *After separating the round cable from the side metal wires for approx. 40-50 cm, run the round cable of the push-button panel through the cable gland of the connector cover.*
- 11- *Remove the sheaths as described for the flat cable and connect the round cable to the male contact block (the one provided with the external contact pins), paying attention to follow the instructions and proceeding in the same order as done for the female contact block.*
- 12- *Fix the male contact block to the connector cover using the four screws placed on the cover edges.*
- 13- *Apply the connector cover to the base matching the two contact blocks, then tighten it with the levers for STANDARD connectors, or with the spring for the CARPEL nylon connector.*
- 14- *Be sure the round cable completes an entire revolution, then fix a side wire to each tie rod plate.*
- 15- *Fix the metal side wires to the round cable at the point where they meet, using a proper fastening clamp, thus avoiding the side wires to be further separated from the round cable during the operation.*
- 16- *Fix the round cable to a side wire using a proper fastening clamp in a point where the cable is idle running. This operation, besides assuring a cable idle running, is required to prevent the cable traction affecting the contacts inside the connector during the operations, instead of distributing on the metal wires.*
- 17- *Tighten the cable gland placed on the connector cover by turning the cable gland screw, thus avoiding any dust or other foreign matters to enter.*

*By* CARPEL<sup>®</sup>   
srl



## LINEA PORTACAVI "TIPO 2000" CABLE CARRYING LINE "TYPE 2000"

La linea portacavi tipo 2000 è un sistema pratico, efficiente e sicuro per la distribuzione dell'energia, sia essa elettrica, pneumatica o altro, per apparecchi mobili quali gru, carri ponti etc.

In questo catalogo troverete sicuramente la soluzione più adatta al vostro problema potendo scegliere tra più linee di carrelli portacavi tutti normalizzati per scorrere in maniera sicura, efficiente e duratura all'interno della canalina di nostra produzione.

Qualunque sia la scelta da voi operata, sarà una scelta di qualità e sicurezza in quanto su tutte le linee troverete apposto il marchio "CE" a garanzia che i nostri prodotti rispondono ai requisiti dettati dalla Direttiva Macchine 89/932 CEE e successivi emendamenti.

*The cable carrying line type "2000" is a handy, efficient and safe system for electrical, pneumatic and other energy distribution to mobile equipment such as cranes, overhead traveling cranes, etc.*

*This catalogue includes various cable carrying lines; among them you will surely find the most suitable to your requirements. You may choose among several lines of cable carrying trolleys, all of them being standardized for assuring a safe, efficient and lasting sliding operation inside our cable raceway.*

*Regardless of your choice, it will assure you quality and safety; all our lines have been labelled with the "CE" mark, to guarantee that our products meet the 89/932/EEC Machinery Directive and further amendments.*



Ci riserviamo la facoltà di apportare, senza alcun preavviso, modifiche costruttive al fine di migliorare le qualità tecniche, funzionali ed estetiche del prodotto.

*We reserve the right to make modifications in order to improve the technical, functional and aesthetical qualities of our products without any prior notice.*



AZIENDA CON SISTEMA QUALITÀ  
CERTIFICATO DA DNV  
=UNI EN ISO 9001/2000=



**LINEA PORTACAVI "TIPO 2000"**  
**CABLE CARRYING LINE "TYPE 2000"**



**Canalina Portacavo**  
**Cable carrying raceway**

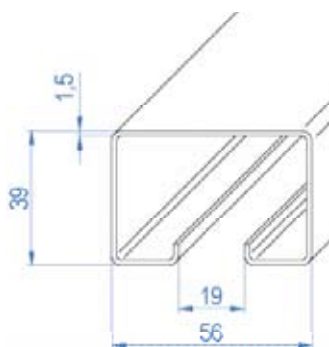
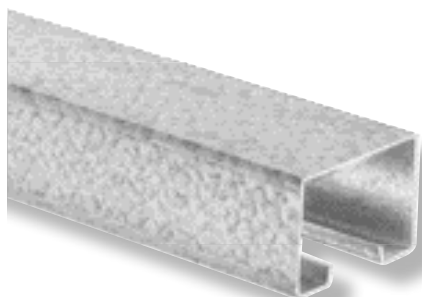

Materiale/Material	Acciaio zincato/Galvanized Steel
	Acciaio inox/Stainless steel
Spessore/Thickness	1,5 mm
Momento d'inerzia/Moment of inertia	6,7 cm <sup>4</sup>
Momento resistente/Resisting moment	3,1 cm <sup>3</sup>
Peso/Weight	2 kg/m
Distanza sospensioni/Suspension distance	2 m
Portata/Capacity	40 kg ogni/every 1,5 m

Articolo/Item	1
Codice barre/Bar code 3	CAN 2000 3
Codice barre/Bar code 3 m INOX	CAN 3M INOX
Codice barre/Bar code 4	CAN 2000 4
Codice barre/Bar code 5	CAN 2000 5
Codice barre/Bar code 6	CAN 2000 6

**Testata semplice in nylon**  
**Nylon simple head**



Materiale/Material	Corpo in nylon/Nylon body
	Acciaio zincato o inox/Galvanized steel or stainless steel
Peso/Weight	70 g

Articolo/Item	06
Codice/Code	TS 2 SEMPN
Codice/Code	TS 2 SEMPN I

**Testata semplice in acciaio**  
**Steel simple head**

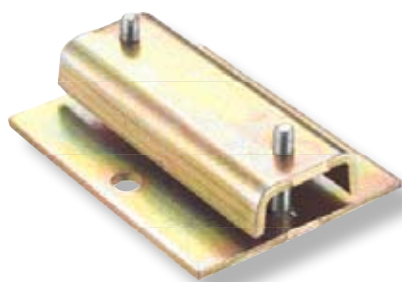

Materiale/Material	Acciaio zincato/Galvanized Steel
	Acciaio inox/Stainless steel
Peso/Weight	175 g

Articolo/Item	06
Codice/Code	TS 2 SEMPA
Codice/Code	TS 2 SEMPA I

**Sospensione con fissaggio laterale**  
**Suspension with side fixing**

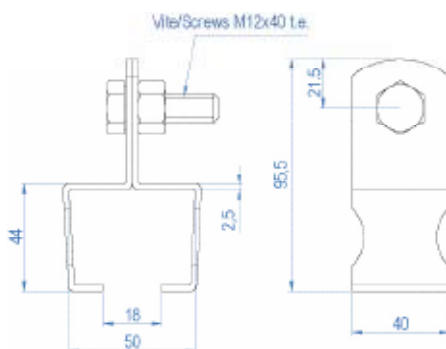

Materiale/Material	Acciaio zincato/Galvanized Steel	
	Acciaio inox/Stainless steel	
	con viti with screws	senza viti without screws
Peso/Weight	240 g	180 g
Portata/Capacity	35 kg	35 kg

<b>Articolo/Item</b>	<b>04</b>	<b>05</b>
Codice/Code	SOS 2 FLCV	SOS 2 FLSV
Codice/Code	SOS 2 FLCV I	SOS 2 FLSV I

**Sospensione con fissaggio a parete**  
**Suspension with wall fixing**

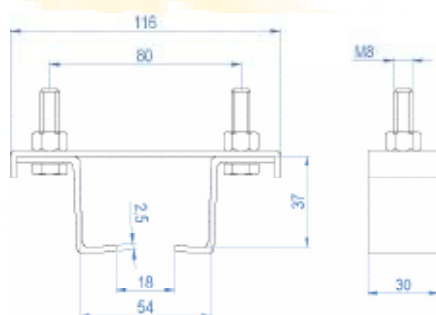
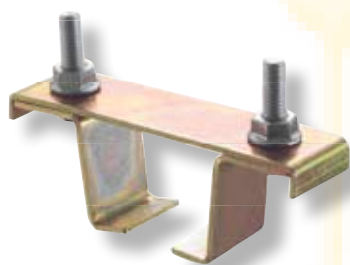

Materiale/Material	Acciaio zincato/Galvanized Steel	
	Acciaio inox/Stainless steel	
	con viti with screws	senza viti without screws
Peso/Weight	180 g	135 g
Portata/Capacity	50 kg	50 kg

<b>Articolo/Item</b>	<b>05+05</b>	<b>05+05</b>
Codice/Code	SOS 2 PACV	SOS 2 PASV
Codice/Code	SOS 2 PACV I	SOS 2 PASV I

**Sospensione a parete con fissaggio di tipo composto**  
**Wall suspension with built-up fixing system**

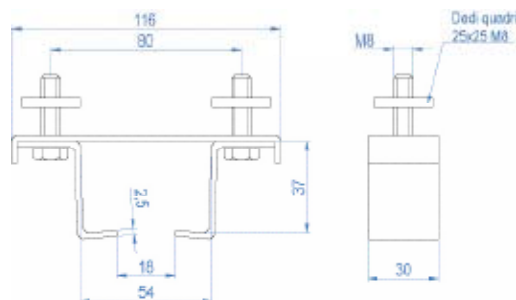
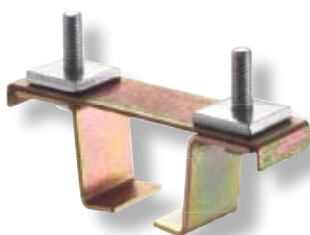

Materiale/Material	Acciaio zincato/Galvanized Steel	
Peso/Weight		195 g
Portata/Capacity		50 kg

<b>Articolo/Item</b>	<b>05+05/C</b>
Codice/Code	SOS 2 PATC

**Giunto doppio in acciaio**  
**Double steel joint**

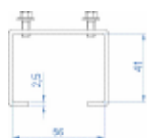
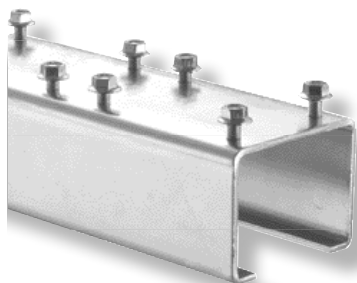

Materiale/Material	Acciaio zincato/Galvanized Steel
	Acciaio inox/Stainless steel
Peso/Weight	520 g

<b>Articolo/Item</b>	<b>03</b>
Codice/Code	GIU 2 FD
Codice/Code	GIU 2 FD I

**Giunto semplice in acciaio**  
**Simple steel joint**

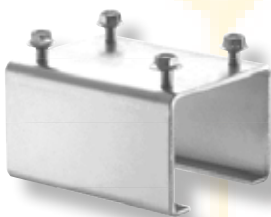

Materiale/Material	Acciaio zincato/Galvanized Steel
	Acciaio inox/Stainless steel
Peso/Weight	260 g

<b>Articolo/Item</b>	<b>02</b>
Codice/Code	GIU 2 FS
Codice/Code	GIU 2 FS I

**Testata con sella**  
Head with saddle

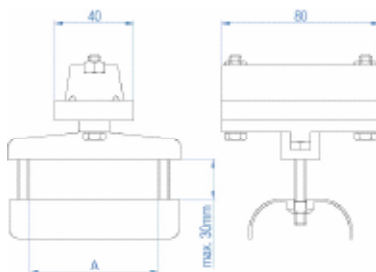

Materiale/Material	Corpo in nylon/Nylon body
Min. in acciaio zinc. o inox/Small parts in galvanized steel or stainless steel	
Portata/Capacity	30 kg

Sella/Saddle	Peso/Weight	Codice/Code	Articolo/Item
A= 35 mm	150 g	TSN2P35	<b>301</b>
A= 50 mm	165 g	TSN2P50	<b>302</b>
A= 65 mm	175 g	TSN2P65	<b>303</b>
A= 65 mm	175 g	TSN2P65I	<b>303</b>

**Carrello portacavi**  
Cable carrying trolley

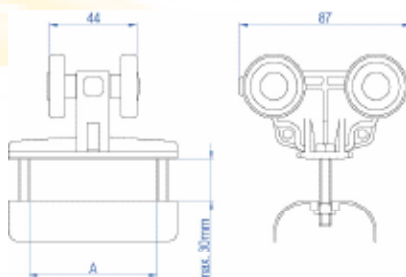

Materiale/Material	Corpo in nylon/Nylon body
Min. in acciaio zinc. o inox/Small parts in galvanized steel or stainless steel	

Ruote Nylon/Nylon Wheels	Ø 33 mm
Portata/Capacity	20 kg

Sella/Saddle	Peso/Weight	Codice/Code	Articolo/Item
A= 35 mm	140 g	CRN2P35N	<b>321</b>
A= 50 mm	150 g	CRN2P50N	<b>322</b>
A= 65 mm	160 g	CRN2P65N	<b>323</b>
A= 65 mm	160 g	CRN2P65NI	<b>323</b>

Cuscinetti rivestiti in nylon/Nylon coated bearing	Ø 32 mm
Portata/Capacity	25 kg

Sella/Saddle	Peso/Weight	Codice/Code	Articolo/Item
A= 35 mm	215 g	CRN2P35C	<b>351</b>
A= 50 mm	230 g	CRN2P50C	<b>352</b>
A= 65 mm	240 g	CRN2P65C	<b>353</b>
A= 65 mm	240 g	CRN2P65CI	<b>353</b>

**Traino**  
Trailer

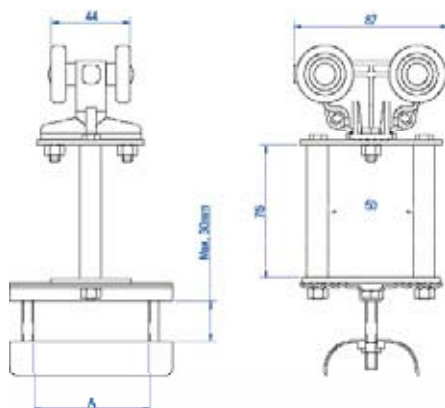

Materiale/Material	Corpo in nylon/Nylon body
Min. in acciaio zinc. o inox/Small parts in galvanized steel or stainless steel	

Ruote Nylon/Nylon Wheels	Ø 33 mm
Portata/Capacity	15 kg

Sella/Saddle	Peso/Weight	Codice/Code	Articolo/Item
A= 35 mm	160 g	TRN2P35N	<b>331</b>
A= 50 mm	170 g	TRN2P50N	<b>332</b>
A= 65 mm	180 g	TRN2P65N	<b>333</b>
A= 65 mm	180 g	TRN2P65NI	<b>333</b>

Cuscinetti rivestiti in nylon/Nylon coated bearing	Ø 32 mm
Portata/Capacity	20 kg

Sella/Saddle	Peso/Weight	Codice/Code	Articolo/Item
A= 35 mm	235 g	TRN2P35C	<b>341</b>
A= 50 mm	245 g	TRN2P50C	<b>342</b>
A= 65 mm	260 g	TRN2P65C	<b>343</b>
A= 65 mm	260 g	TRN2P65C I	<b>343</b>

## LINEA PORTACAVI "TIPO 2000" CABLE CARRYING LINE "TYPE 2000"



### Testata con sella Head with saddle

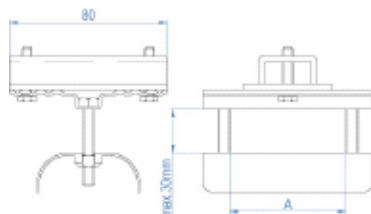
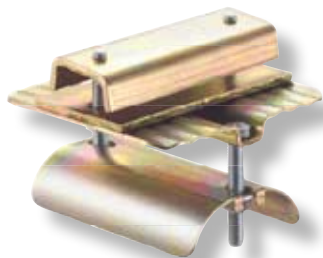

Materiale/Material	Corpo e Minuteria in acciaio zincato o inox Body and Small parts in galvanized steel or in stainless steel
Portata/Capacity	40 kg

Sella/Saddle	Peso/Weight	Codice/Code	Articolo/Item
A= 25 mm	255 g	TSA2P25	<b>401</b>
A= 35 mm	275 g	TSA2P35	<b>402</b>
A= 55 mm	300 g	TSA2P55	<b>403</b>
A= 65 mm	315 g	TSA2P65-TSA2P65 I	<b>404</b>
A= 80 mm	335 g	TSA2P80	<b>405</b>
A= 100 mm	365 g	TSA2P10	<b>406</b>

### Carrello portacavi Cable carrying trolley

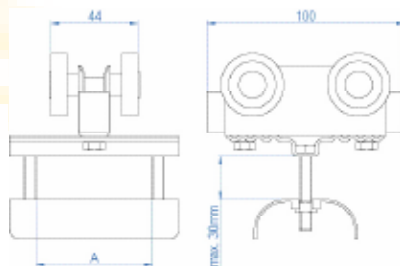

Materiale/Material	Corpo e Minuteria in acciaio zincato o inox Body and Small parts in galvanized steel or in stainless steel
--------------------	---

Ruote Nylon/Nylon Wheels	Ø 33 mm
Portata/Capacity	30 kg

Sella/Saddle	Peso/Weight	Codice/Code	Articolo/Item
A= 25 mm	255 g	CRA2P25N	<b>421</b>
A= 35 mm	275 g	CRA2P35N	<b>422</b>
A= 55 mm	290 g	CRA2P55N	<b>423</b>
A= 65 mm	320 g	CRA2P65N-CRA2P65NI	<b>424</b>
A= 80 mm	335 g	CRA2P80N	<b>425</b>
A= 100 mm	360 g	CRA2P10N	<b>426</b>

Cuscinetti in acciaio/Steel bearing	Ø 32 mm
Portata/Capacity	35 kg

Sella/Saddle	Peso/Weight	Codice/Code	Articolo/Item
A= 25 mm	330 g	CRA2P25C	<b>451</b>
A= 35 mm	350 g	CRA2P35C	<b>452</b>
A= 55 mm	365 g	CRA2P55C	<b>453</b>
A= 65 mm	395 g	CRA2P65C-CRA2P65 CI	<b>454</b>
A= 80 mm	410 g	CRA2P80C	<b>455</b>
A= 100 mm	435 g	CRA2P10C	<b>456</b>

### Traino Trailer

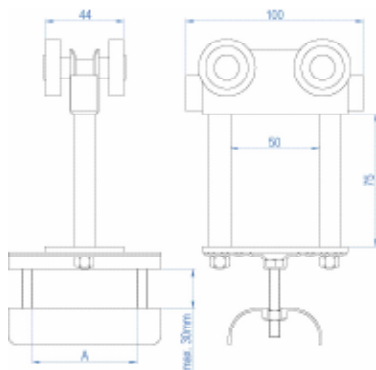

Materiale/Material	Corpo e Minuteria in acciaio zincato o inox Body and Small parts in galvanized steel or in stainless steel
--------------------	---

Ruote Nylon/Nylon Wheels	Ø 33 mm
Portata/Capacity	25 kg

Sella/Saddle	Peso/Weight	Codice/Code	Articolo/Item
A= 25 mm	355 g	TRA2P25N	<b>431</b>
A= 35 mm	375 g	TRA2P35N	<b>432</b>
A= 55 mm	400 g	TRA2P55N	<b>433</b>
A= 65 mm	415 g	TRA2P65N-TRA2P65NI	<b>434</b>
A= 80 mm	435 g	TRA2P80N	<b>435</b>
A= 100 mm	460 g	TRA2P10N	<b>436</b>

Cuscinetti in acciaio/Steel bearing	Ø 32 mm
Portata/Capacity	30 kg

Sella/Saddle	Peso/Weight	Codice/Code	Articolo/Item
A= 25 mm	435 g	TRA2P25C	<b>441</b>
A= 35 mm	455 g	TRA2P35C	<b>442</b>
A= 55 mm	480 g	TRA2P55C	<b>443</b>
A= 65 mm	495 g	TRA2P65C-TRA2P65C I	<b>444</b>
A= 80 mm	515 g	TRA2P80C	<b>445</b>
A= 100 mm	540 g	TRA2P10C	<b>446</b>

**Testata sella girevole**  
Head with slewing saddle

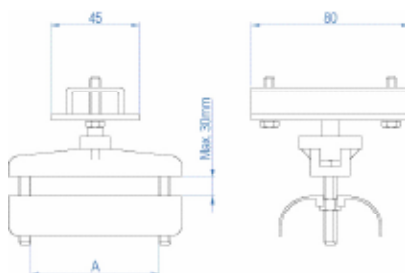
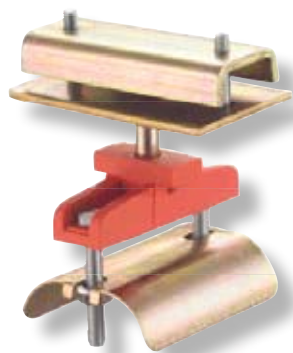

Materiale/ Material	Acciaio zincato/ Galvanized Steel
Portata/ Capacity	30 kg

Sella/ Saddle	Peso/ Weight	Codice/ Code	Articolo/ Item
A= 35 mm	315 g	TSA2P35SG	<b>402-G</b>
A= 50 mm	340 g	TSA2P55SG	<b>403-G</b>
A= 65 mm	355 g	TSA2P65SG	<b>404-G</b>

**Carrello sella girevole**  
Trolley with slewing saddle

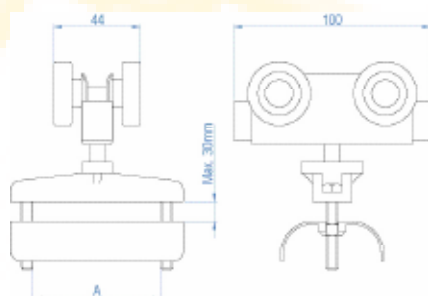
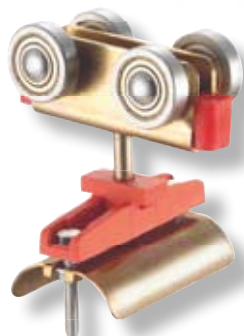

Materiale/ Material	Acciaio zincato/ Galvanized Steel
Ruote/ Wheels	Cuscinetti acciaio/ Steel bearings Ø 32 mm
Portata/ Capacity	25 kg

Sella/ Saddle	Peso/ Weight	Codice/ Code	Articolo/ Item
A= 35 mm	390 g	CRA2P35SG	<b>452-G</b>
A= 50 mm	405 g	CRA2P55SG	<b>453-G</b>
A= 65 mm	435 g	CRA2P65SG	<b>454-G</b>

**Traino sella girevole**  
Trailer with slewing saddle

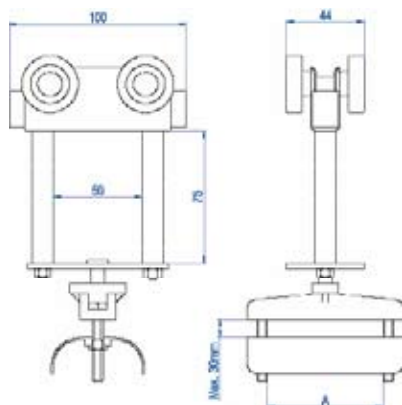

Materiale/ Material	Acciaio zincato/ Galvanized Steel
Ruote/ Wheels	Cuscinetti acciaio/ Steel bearings Ø 32 mm
Portata/ Capacity	20 kg

Sella/ Saddle	Peso/ Weight	Codice/ Code	Articolo/ Item
A= 35 mm	490 g	TRA2P35SG	<b>442-G</b>
A= 50 mm	505 g	TRA2P55SG	<b>443-G</b>
A= 65 mm	535 g	TRA2P65SG	<b>444-G</b>

**Testata con morsetto**  
**Head with clamp**

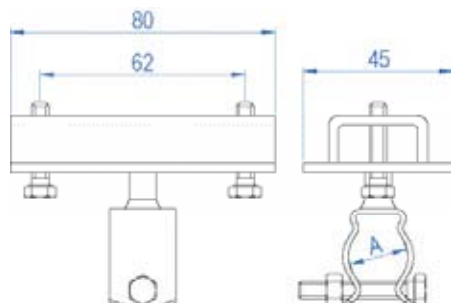
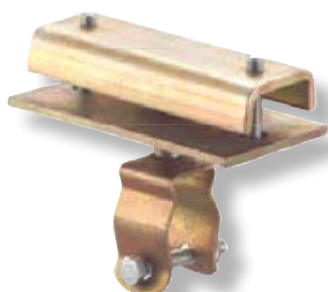

Materiale/Material	Acciaio zincato/Galvanized Steel
Portata/Capacity	30 kg
A (Ø max cavo/Cable max)	22 mm
Peso/Weight	205 g

<b>Articolo/Item</b>	<b>602</b>
Codice/Code	TSA 2 M22

**Carrello con morsetto**  
**Trolley with clamp**

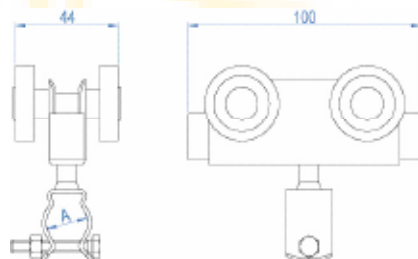
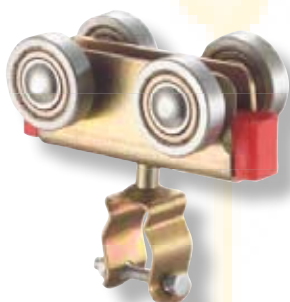

Materiale/Material	Acciaio zincato/Galvanized Steel
Ruote/Wheels	Nylon Ø 33 mm
	Cuscinetti acciaio/Steel bearings Ø 32 mm
A (Ø max cavo/Cable max)	22 mm

	Ruote nylon	Ruote cuscinetto
	Nylon wheels	Wheels with bearing
Peso/Weight	195 g	270 g
Portata/Capacity	20 kg	25 kg

<b>Articolo/Item</b>	<b>603</b>	<b>604</b>
Codice/Code	CRA 2 M22N	CRA 2 M22C

**Traino con morsetto**  
**Trailer with clamp**

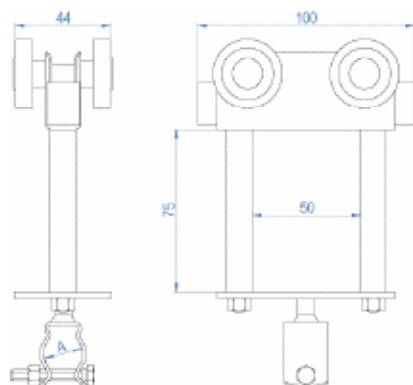

Materiale/Material	Acciaio zincato/Galvanized Steel
Ruote/Wheels	Nylon Ø 33 mm
	Cuscinetti acciaio/Steel bearings Ø 32 mm
A (Ø max cavo/Cable max)	22 mm

	Ruote nylon	Ruote cuscinetto
	Nylon wheels	Wheels with bearing
Peso/Weight	380 g	455 g
Portata/Capacity	15 kg	20 kg

<b>Articolo/Item</b>	<b>631</b>	<b>632</b>
Codice/Code	TRA 2 M22N	TRA 2 M22C

**Connettore per cavo piatto - presa tipo CARPEL**  
Connector for flat cable - socket type CARPEL

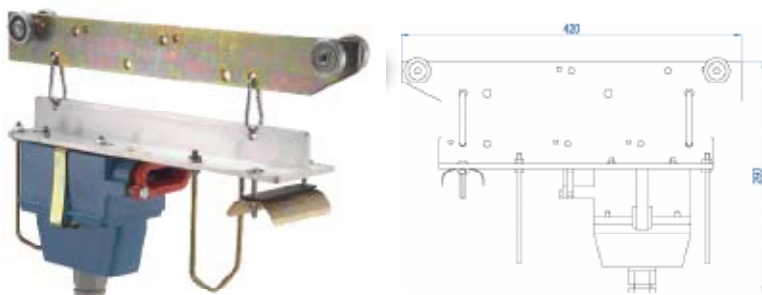

Materiale/Material	Piastra in alluminio/Aluminium plate		
	Presa in nylon/Nylon socket		
	Stecca in acciaio zincato/Galvanized steel slat		
	Minuteria in acciaio zincato/Small parts in galvanized steel		
Ruote/Wheels	Cuscinetti acciaio/Steel bearings Ø 32 mm		
Portata/Capacity	40 kg		
Peso/Weight	2900 g		

Articolo/Item	1009	1010	1011
Codice/Code	CON 2 P10	CON 2 P16	CON 2 P24
	10 Poli/Pole	16 Poli/Pole	24 Poli/Pole

**Connettore per cavo piatto - presa tipo STANDARD**  
Connector for flat cable - socket type STANDARD

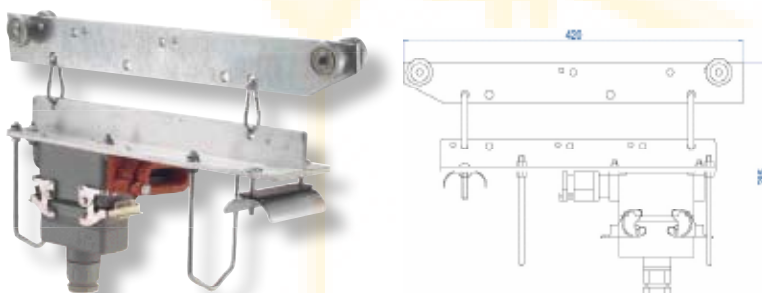

Materiale/Material	Piastra in alluminio/Aluminium plate			
	Presa in alluminio/Aluminium socket			
	Stecca in acciaio zincato/Galvanized steel slat			
	Minuteria in acciaio zincato/Small parts in galvanized steel			
Ruote/Wheels	Cuscinetti acciaio/Steel bearings Ø 32 mm			
Portata/Capacity	40 kg			
Peso/Weight	2660 g			

Articolo/Item	1029	1030	1031	1032
Codice/Code	CON 2 P10I	CON 2 P16I	CON 2 P24I	CON 2 P32I
	10 Poli/Pole	16 Poli/Pole	24 Poli/Pole	32 Poli/Pole

**Connettore per cavo tondo - presa tipo STANDARD**  
Connector for round cable - socket type STANDARD

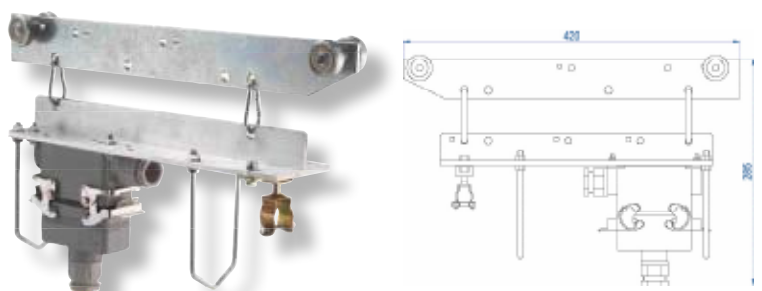

Materiale/Material	Piastra in alluminio/Aluminium plate			
	Presa in alluminio/Aluminium socket			
	Stecca in acciaio zincato/Galvanized steel slat			
	Minuteria in acciaio zincato/Small parts in galvanized steel			
Ruote/Wheels	Cuscinetti acciaio/Steel bearings Ø 32 mm			
Portata/Capacity	40 kg			
Peso/Weight	2885 g			

Articolo/Item	1019	1020	1021	1022
Codice/Code	CON 2 T10	CON 2 T16	CON 2 T24	CON 2 T32
	10 Poli/Pole	16 Poli/Pole	24 Poli/Pole	32 Poli/Pole



**Traino speciale**  
Special trailer

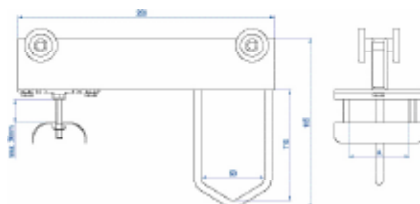

Materiale/Material *Acciaio zincato/Galvanized Steel*

Ruote Nylon/Nylon Wheels  $\varnothing$  33 mm

Portata/Capacity 35 kg

Sella/Saddle	Peso/Weight	Codice/Code	Articolo/Item
A= 25 mm	695 g	TRP2P25N	<b>RN25</b>
A= 40 mm	735 g	TRP2P40N	<b>RN40</b>
A= 55 mm	765 g	TRP2P55N	<b>RN55</b>
A= 65 mm	785 g	TRP2P65N	<b>RN65</b>
A= 85 mm	855 g	TRP2P85N	<b>RN85</b>
A= 100 mm	890 g	TRP2P10N	<b>RN10</b>

Cuscinetti in acciaio/Steel bearing  $\varnothing$  32 mm

Portata/Capacity 40 kg

Sella/Saddle	Peso/Weight	Codice/Code	Articolo/Item
A= 25 mm	765 g	TRP2P25C	<b>RC25</b>
A= 40 mm	805 g	TRP2P40C	<b>RC40</b>
A= 55 mm	835 g	TRP2P55C	<b>RC55</b>
A= 65 mm	855 g	TRP2P65C	<b>RC65</b>
A= 85 mm	925 g	TRP2P85C	<b>RC85</b>
A= 100 mm	960 g	TRP2P10C	<b>RC10</b>

**Traino con sella centrale**  
Trailer with central saddle

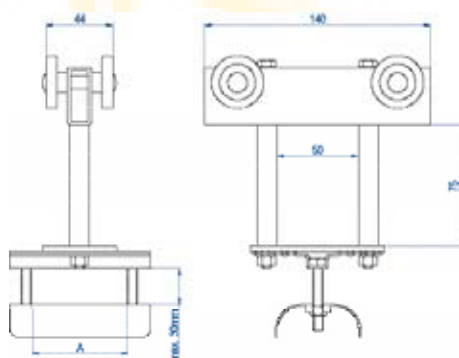
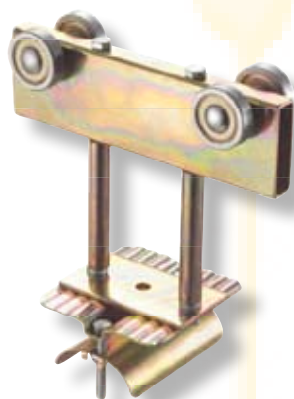

Materiale/Material *Acciaio zincato/Galvanized Steel*

Ruote/Wheels Cuscinetti acciaio/Steel bearings  $\varnothing$  32 mm

Portata/Capacity 35 kg

Sella/Saddle	Peso/Weight	Codice/Code	Articolo/Item
A= 25 mm	545 g	TR2SCS25	<b>225</b>
A= 35 mm	585 g	TR2SCS35	<b>235</b>
A= 55 mm	615 g	TR2SCS55	<b>255</b>
A= 65 mm	635 g	TR2SCS65	<b>265</b>
A= 85 mm	705 g	TR2SCS85	<b>280</b>
A= 100 mm	740 g	TR2SCS10	<b>210</b>

**Griffa portacavi**  
Cable carrying claw

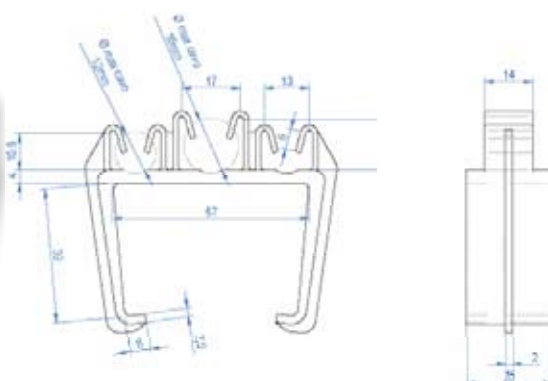

Materiale/Material Nylon

Peso/Weight 20 g

**Articolo/Item 4202**

Codice/Code GRIFFA/2000



## **ISTRUZIONI DI MONTAGGIO - linea con traino -**

### **ASSEMBLY INSTRUCTIONS - line with trailer -**

- 1- Posizionare le sospensioni nelle proprie sedi (pareti o mensole); in questa fase di montaggio non bisogna stringere eccessivamente le viti delle sospensioni, in modo da permettere l'inserimento delle barre di canalina ed il loro eventuale posizionamento.
- 2- Inserire le barre di canalina nelle sospensioni; verificare la presenza di un numero adeguato di sospensioni su tutta la linea.  
In questa fase è necessario prestare particolare attenzione allo “spigolo vivo” del taglio della canalina: tale spigolo è necessario per un corretto allineamento delle parti di canalina da unire e per far scorrere correttamente il carrello all'interno.
- 3- Applicare i giunti alle estremità delle barre, quindi serrare le viti senza deformare la canalina. Le estremità delle canaline devono essere adiacenti e ben allineate (la conformazione del giunto impedisce il non allineamento delle canaline) onde evitare che il carrello durante la corsa urti contro l'estremità della canalina e che, con il passare del tempo, sia pregiudicato il buon funzionamento del carrello stesso.
- 4- Serrare tutte le viti delle sospensioni verificando nel medesimo tempo il bloccaggio dell'intera linea.
- 5- Verificare l'allineamento dell'intera linea.
- 6- Inserire la prima testata (senza sella) e fissarla all'estremità opposta a quella in cui la linea si allaccerà all'alimentazione.
- 7- Inserire il traino nella canalina nell'estremità senza testata.
- 8- Di seguito, nello stesso modo, inserire tutti i carrelli che sosterranno il cavo di alimentazione
- 9- Posizionare la testata rimanente (con sella) e fissarla in modo da chiudere la linea. La chiusura della linea impedisce la fuoriuscita del traino e dei carrelli.
- 10- Inserire il cavo conduttore nel carrello, tra sella e controsella, partendo dalla testata con la sella sino ad arrivare al traino.
- 11- Stringere le viti del carrello, fissando il cavo tra sella e controsella, avendo cura di verificare che non sia presente movimento di scorrimento del cavo nel carrello.
- 12- Lasciare tra carrello e carrello una quantità di cavo pari all'ansa desiderata.

- 1- Place the suspensions into their seats (walls or brackets), without overtightening the suspension screws so as to allow the raceway bars to be inserted and positioned, if necessary.
- 2- Insert the raceway bars into the suspensions; be sure that a proper number of suspensions are all over the line.  
In this phase particular attention has to be paid to the “sharp edge” of the raceway cutting side: such an edge is required to properly align the raceway parts to be connected and for the trolley to properly slide inside.
- 3- Apply the joints to the bar ends, then tighten the screws without deforming the raceway. The raceway ends must be adjacent and well aligned (the joint configuration avoids the raceway misalignment) preventing the trolley to strike the raceway ends during its stroke and the trolley to properly work in the time.
- 4- Tighten all the suspension screws while checking that all the line is locked.
- 5- Verify that all the line is properly aligned.
- 6- Insert the first head (without the saddle), fixing it at the end opposite to that where the line will be connected to the feeding line.
- 7- Insert the trailer into the raceway at the headless end.
- 8- Insert now all the trolleys that will have to carry the feeding cable, proceeding the same way as above.
- 9- Position the remaining head (with the saddle) and fix it in such a way that the line is closed. The line closing prevents the trailer and the trolleys to come out.
- 10- Insert the conductor cable into the trolley, between the saddle and the countersaddle. Start inserting the saddle from the head until reaching the trailer.
- 11- Tighten the trolley screws fixing the cable between the saddle and the countersaddle, paying attention so as the cable into the trolley does not slide at all.
- 12- Leave a quantity of cable between each trolley equal to the required loop.

## **ISTRUZIONI DI MONTAGGIO - linea con pulsantiera -** **ASSEMBLY INSTRUCTIONS - line with push-button panel -**

Nel caso si debba montare la linea di azionamento comandi il procedimento è simile al precedente, avendo però l'accortezza di inserire al posto del traino (precedente punto 7) il connettore. Il montaggio del connettore avviene nel modo seguente:

- 1- Preparare il cavo piatto montato sulla linea, eliminando 3 cm circa di guaina esterna e 1 cm circa di guaina per ogni singolo cavetto interno.
- 2- Far passare il cavo piatto tra la sella e la piastra del connettore.
- 3- Aprire il connettore: se si tratta di connettore in nylon (nei colori: arancio, azzurro o giallo), fare leva sull'estremità della molla mediante un utensile (pinza o cacciavite); se si tratta di connettore metallico, premere le due leve esterne in modo da liberare l'aggancio. Rimuovere quindi il coperchio.
- 4- Prendere i frutti all'interno del connettore e separarli, nel caso non lo fossero già.
- 5- Far passare il cavo piatto attraverso il pressacavo posto sulla base del connettore.
- 6- Connettere il cavo piatto della linea al frutto femmina (frutto senza i pioli di contatto esterni), inserendo i singoli cavetti nelle apposite sedi numerate e serrando le viti relative a ogni sede per bloccare il cavo. La sequenza di connessione dei cavi è a cura dell'installatore a seconda delle proprie esigenze.
- 7- Inserire il frutto femmina nella base del connettore bloccandolo mediante le quattro viti poste agli angoli.
- 8- Serrare le viti del pressacavo sulla base del connettore onde evitare l'ingresso di polvere o altro.
- 9- Serrare le viti della sella lasciando abbondante il cavo tra la sella e il pressacavo.
- 10- Far passare il cavo tondo della pulsantiera attraverso il pressacavo del coperchio del connettore, dopo aver separato, per circa 40-50 cm, il cavo stesso dai cavetti metallici laterali.
- 11- Eliminare le guaine come indicato per il cavo piatto e connettere il cavo tondo al frutto maschio (quello con i pioli di contatto esterni), avendo cura di seguire le istruzioni date per il frutto femmina e seguendo lo stesso ordine di connessione.
- 12- Fissare il frutto maschio al coperchio del connettore utilizzando le quattro viti poste agli angoli dello stesso.
- 13- Applicare il coperchio del connettore alla base, avendo cura di far coincidere i due frutti, quindi serrarlo utilizzando le leve, per i connettori di tipo STANDARD, o la molla, per connettore tipo CARPEL in nylon.
- 14- Far compiere al cavo tondo un giro completo, quindi fissare un cavetto laterale a ciascun tirante della piastra.
- 15- Per mezzo di una fascetta fissare i cavetti laterali metallici al cavo tondo nel punto in cui questi si incontrano, evitando così che durante l'utilizzo i cavetti laterali si separino ulteriormente dal cavo tondo.
- 16- Fissare ad un cavetto laterale il cavo tondo per mezzo di una fascetta in un punto del giro a vuoto del cavo. Questa operazione, unita a lasciare un giro a vuoto di cavo, è necessaria per evitare che durante l'utilizzo il tiro sul cavo vada a ripercuotersi sui contatti all'interno del connettore, anziché distribuirsi sui cavetti metallici.
- 17- Serrare il pressacavo posto sul coperchio del connettore girando la vite del pressacavo stesso al fine di evitare l'ingresso di polvere o altro.

*Should the drive controls line be installed, the process is similar to the previous one but the connector must be inserted instead of the trailer (see previous point 7). Install the connector as follows:*

- 1- Mount the flat cable on the line and remove approx. 3 cm of external sheath and approx. 1 cm of sheath for each inside wire.
- 2- Run the flat cable between the saddle and the connector plate.
- 3- Open the connector: should it be a nylon one (orange, light blue or yellow coloured) lever, by a proper tool (pliers or screwdriver), the spring end. Should it be a metal connector (grey coloured), press the two external levers for releasing the coupling. Remove the cover.
- 4- Take the contact blocks inside the connector. Separate them, if necessary.
- 5- Run the flat cable through the cable gland placed on the connector base.
- 6- Connect the line flat cable to the female contact block (contact block without the external contact pins) by inserting the single wires into the proper numbered seats. Fix the cable by tightening the relevant screws to each seat. The cable connection sequence is provided by the installer according to his own requirements.
- 7- Insert the female contact block into the connector base and lock it by the four screws placed at the edges.
- 8- Tighten the cable gland screws to the connector base, thus preventing any dust or other foreign matters to enter.
- 9- Tighten the saddle screws paying attention to leave a big quantity of cable between the saddle and the cable gland.
- 10- After separating the round cable from the side metal wires for approx. 40-50 cm, run the round cable of the push-button panel through the cable gland of the connector cover.
- 11- Remove the sheaths as described for the flat cable and connect the round cable to the male contact block (the one provided with the external contact pins), paying attention to follow the instructions and proceeding in the same order as done for the female contact block.
- 12- Fix the male contact block to the connector cover using the four screws placed on the cover edges.
- 13- Apply the connector cover to the base matching the two contact blocks, then tighten it with the levers for STANDARD connectors, or with the spring for the CARPEL nylon connector.
- 14- Be sure the round cable completes an entire revolution, then fix a side wire to each tie rod plate.
- 15- Fix the metal side wires to the round cable at the point where they meet, using a proper fastening clamp, thus avoiding the side wires to be further separated from the round cable during the operation.
- 16- Fix the round cable to a side wire using a proper fastening clamp in a point where the cable is idle running. This operation, besides assuring a cable idle running, is required to prevent the cable traction affecting the contacts inside the connector during the operations, instead of distributing on the metal wires.
- 17- Tighten the cable gland placed on the connector cover by turning the cable gland screw, thus avoiding any dust or other foreign matters to enter.

*By* CARPEL<sup>®</sup> srl 

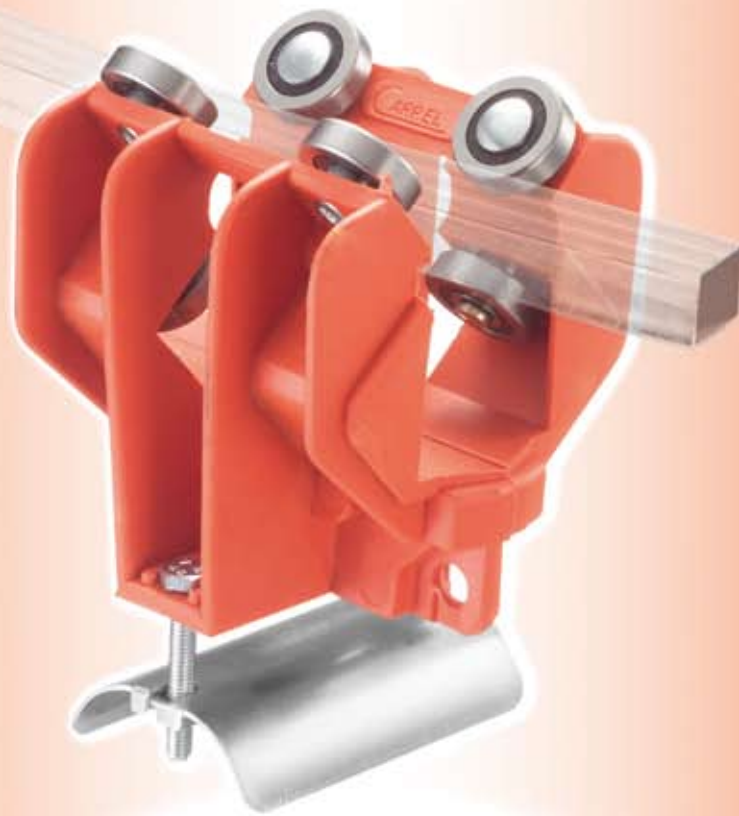

## LINEA A TUBO QUADRO “TIPO 1800” SQUARE TUBE LINE “TYPE 1800”

La linea “1800” consente l’alimentazione di tutte quelle apparecchiature mobili il cui movimento di traslazione non è rettilineo ma presenta curve e controcurve, anche con raggio relativamente piccolo, senza causare inconvenienti quali sbandamenti o impuntamenti dei carrelli; questo grazie alla speciale conformazione degli stessi, appositamente studiati per scorrere in maniera facile e sicura lungo i quattro lati del profilo quadrangolare. Per questo motivo la linea 1800 a tubo quadro si presenta come scelta ideale per il trasporto flessibile di energia quale: elettrica, pneumatica, gassosa ed idraulica per l’alimentazione di paranchi, carri ponte, macchine operatrici speciali, etc.

Inoltre, per linee di alimentazione molto lunghe, con scarsa possibilità di raccolta dei carrelli, è possibile, utilizzando la linea “1800”, progettare il garage di raccolta carrelli trasversalmente alla via di corsa. Scegliendo la linea 1800 a tubo quadro per alimentare il vostro apparecchio mobile, farete una scelta di qualità e sicurezza, in quanto sulla stessa troverete apposto il marchio “CE” a garanzia che il prodotto risponde ai requisiti dettati dalla Direttiva Macchine 89/932 CEE e successivi emendamenti.

*The line “1800” allows all those mobile equipment not featuring a straight traverse movement, but presenting bends and reverse bends, even with fairly reduced radius, to be fed without causing faults like as deviations and sticking of the trolleys. This is due to the special configuration of the trolleys that are properly designed to easily and safely slide all along the four quadrangular profile sides. This is the reason why the square tube line “1800” is the ideal solution for facing the requirements for flexible transport of electrical, pneumatic, gas and hydraulic energy meant for feeding hoists, traveling overhead cranes, special machine tools, etc. And what is more, in case of particularly long feeding lines featuring short possibilities for trolleys collection, the line “1800” grants the possibility to design the trolley collection garage crosswise the runway. Choosing the square tube line “1800” for feeding your mobile equipment, it will assure you quality and safety; it has been labelled with the “CE” mark to guarantee that the product meets the 89/932/EEC Machinery Directive and further amendments.*

**By CARPEL**  srl

Ci riserviamo la facoltà di apportare, senza alcun preavviso, modifiche costruttive al fine di migliorare le qualità tecniche, funzionali ed estetiche del prodotto.

*We reserve the right to make modifications in order to improve the technical, functional and aesthetical qualities of our products without any prior notice.*



AZIENDA CON SISTEMA QUALITÀ  
CERTIFICATO DA DNV  
=UNI EN ISO 9001/2000=

# LINEA A TUBO QUADRO "TIPO 1800"

## SQUARE TUBE LINE "TYPE 1800"



### Profilo a tubo quadro

#### Square tube profile

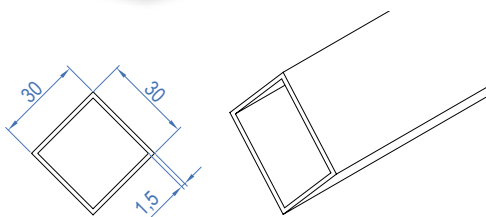

Materiale/Material	Acciaio zincato/Galvanized Steel
	Acciaio inox/Stainless steel
Momento d'inerzia/Moment of inertia	2,32 cm <sup>4</sup>
Momento resistente/Resisting moment	1,09 cm <sup>3</sup>
Peso/Weight	1,76 kg/m
Portata/Capacity	26 kg ogni/ every 1,5 m

#### Articolo/Item 1800

Codice/Code	Acc. zincato/Galvanized Steel	Acc. inox/Stainless steel
Profilo rettilineo/Straight profile	PRTQ 1800	PRTQ 1800 I
Profilo curvilineo/Curvilinear profile	PRTQCURV	PRTQCURV I

Il profilo del tubo quadro viene fornito in moduli standard di 1,5 m, mentre per quanto riguarda il profilo curvilineo viene fornito in moduli più piccoli per un più comodo imballaggio, ma soprattutto per permettere all'installatore di applicare uno o più giunti sospensione all'interno della curva stessa.

The square tube profile is supplied in standard 1,5 m modules. The curvilinear profile is supplied in smaller modules aiming at a more comfortable packing, but mainly for allowing the installer to apply one or more suspensions-joints inside the bend itself.

### Giunto sospensione

#### Suspension joint

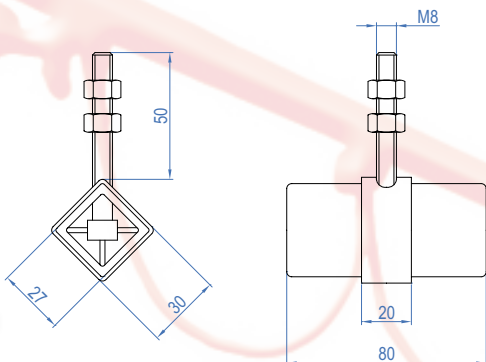
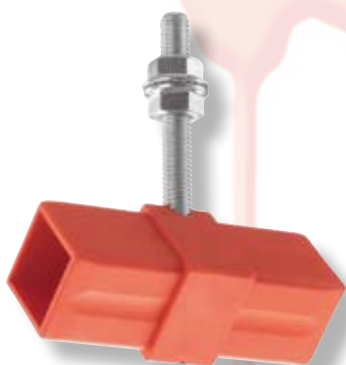

Materiale/Material	Corpo in nylon/Nylon body
	Acciaio zincato o inox/Galvanized steel or stainless
Peso/Weight	75 g
Portata/Capacity	30 Kg

#### Articolo/Item 1805

	Acc. zincato/Galvanized Steel	Acc. inox/Stainless steel
Codice/Code	GSTQ 1805	GSTQ 1805 I

### Testata

#### Head

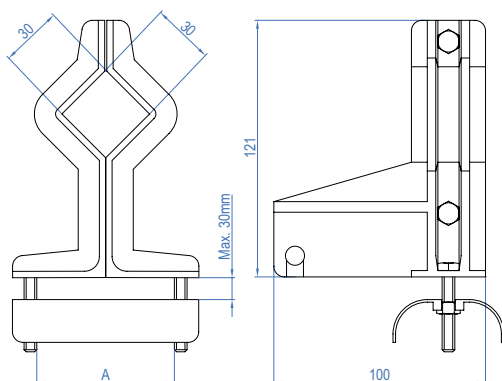

Materiale/Material	Corpo in nylon/Nylon body
	Acciaio zincato o inox/Galvanized steel or stainless
Peso/Weight	220 g
Portata/Capacity	25 Kg

#### Articolo/Item 1801

	Acc. zincato/Galvanized Steel	Acc. inox/Stainless steel
Codice/Code	TSTQ 1801	TSTQ 1801 I

**Carrello con sella**  
**Trolley with saddle**

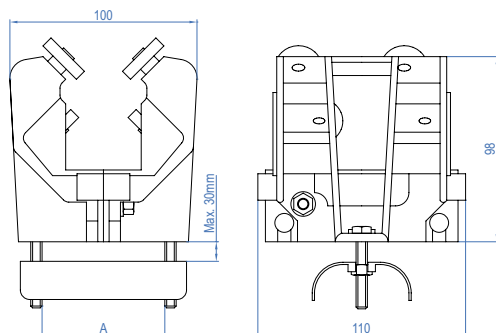

Materiale/ Material	Corpo in nylon/ Nylon body
	Acciaio zincato o inox/ Galvanized steel or stainless
Ruote/ Wheels	Cuscinetti in acciaio/ Steel bearings
Peso/ Weight	415 g
Portata/ Capacity	15 Kg

<b>Articolo/ Item</b>	<b>1802</b>	
	Acc. zincato/ Galvanized Steel	Acc. inox/ Stainless steel
Codice/ Code	CRTQ 1802	CRTQ 1802 I

**Traino**  
**Trailer**

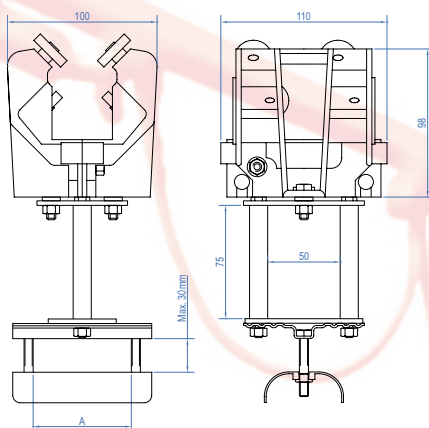
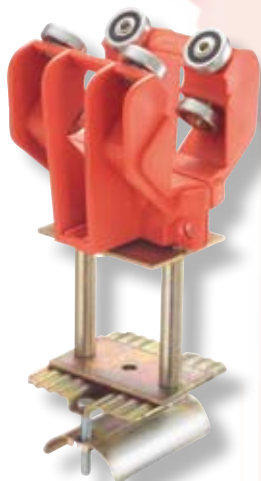

Materiale/ Material	Corpo in nylon/ Nylon body
	Acciaio zincato o inox/ Galvanized steel or stainless
Ruote/ Wheels	Cuscinetti in acciaio/ Steel bearings
Peso/ Weight	825 g
Portata/ Capacity	10 Kg

<b>Articolo/ Item</b>	<b>1803</b>	
	Acc. zincato/ Galvanized Steel	Acc. inox/ Stainless steel
Codice/ Code	TRTQ 1803	TRTQ 1803 I

**Traino doppio**  
**Trailer double**

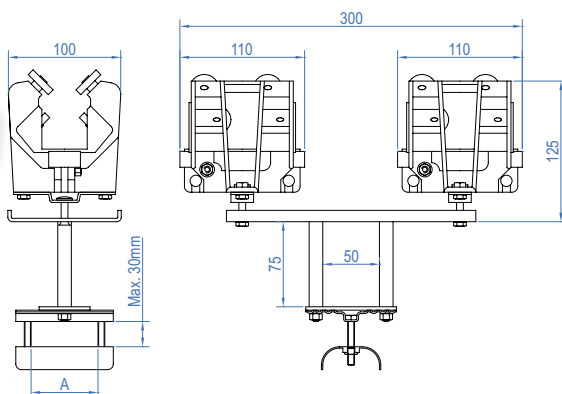
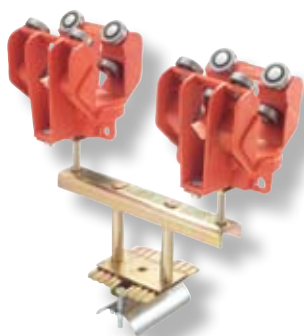

Materiale/ Material	Corpo in nylon/ Nylon body
	Acciaio zincato o inox/ Galvanized steel or stainless
Ruote/ Wheels	Cuscinetti in acciaio/ Steel bearings
Peso/ Weight	1755 g
Portata/ Capacity	10 Kg

<b>Articolo/ Item</b>	<b>1803/2</b>	
	Acc. zincato/ Galvanized Steel	Acc. inox/ Stainless steel
Codice/ Code	TRTQ 1803/2	TRTQ 1803/2 I



**ISTRUZIONI DI MONTAGGIO - Linea "1800" a tubo quadro -**  
**ASSEMBLY INSTRUCTIONS - Square tube line "1800" -**

- 1- Inserire i due giunti-sospensione alle estremità della prima barra di tubo quadro della linea.
- 2- Applicare i giunti-sospensione e la barra alle apposite mensole di sostegno, evitando per il momento di serrare i dadi dei giunti-sospensione.
- 3- Inserire nella barra successiva un giunto-sospensione e quindi applicare la barra stessa di seguito alla precedente.
- 4- Ripetere l'ultima operazione per tutte le barre, fino al completamento della linea.
- 5- Verificare il corretto allineamento della linea e quindi serrare tutti i dadi dei giunti sospensione
- 6- Inserire la prima testata all'estremità della linea dalla parte opposta della scatola di alimentazione, avendo cura di posizionarla con l'elemento di battuta rivolto verso l'interno della linea.
- 7- Inserire, dall'estremità libera della linea, prima il traino e poi tutti i carrelli.
- 8- Inserire la testata all'estremità della linea dalla parte della scatola di alimentazione, rivolgendo l'elemento di battuta verso l'interno della linea.
- 9- Far passare il cavo tra la sella e la controsella degli elementi della linea partendo dalla testata vicino alla scatola di alimentazione arrivando fino al traino, passando per tutti i carrelli.
- 10- Non far passare il cavo tra la sella e la controsella della testata a fine linea, in quanto questo elemento serve solo allo scopo di chiudere la linea, e non di sostenere il cavo.
- 11- Serrare le viti delle selle di tutti gli elementi, avendo cura di lasciare tra elemento e elemento sufficiente cavo per formare l'ansa desiderata e sufficiente cavo prima della testata e dopo il traino per raggiungere i collegamenti da realizzare.

- 1- Insert the two suspension-joints at the ends of the first square tube bar of the line.
- 2- Apply the suspension-joints and the bar to the proper supporting brackets taking care not to tighten the suspension-joint nuts for the moment.
- 3- Insert one suspension-joint into the next bar, then place the bar itself after the previous one.
- 4- Repeat the latest operation for all the bars, until completing the line.
- 5- Make sure the line is properly aligned, then tighten all the suspension joint nuts.
- 6- Insert the first head into the line end from the opposite side of the supply box, paying attention the bearing piece is pointing towards the line inside.
- 7- Insert the trailer first, then all the trolleys, from the line free end.
- 8- Insert the head into the line end from the supply box side, paying attention to place the bearing piece pointing towards the line inside.
- 9- Run the cable between the saddle and countersaddle of the line elements, starting from the head next to the supply box, passing through all the trolleys and ending at the trailer.
- 10- Do not run the cable between the saddle and countersaddle of the head at the end of the line, as this element is only needed for closing the line and not for holding the cable.
- 11- Tighten all the saddle screws in all elements, paying attention to leave enough cable length between the elements to form the required loop and enough length of cable before the head and after the trailer to reach the connections to be carried out.

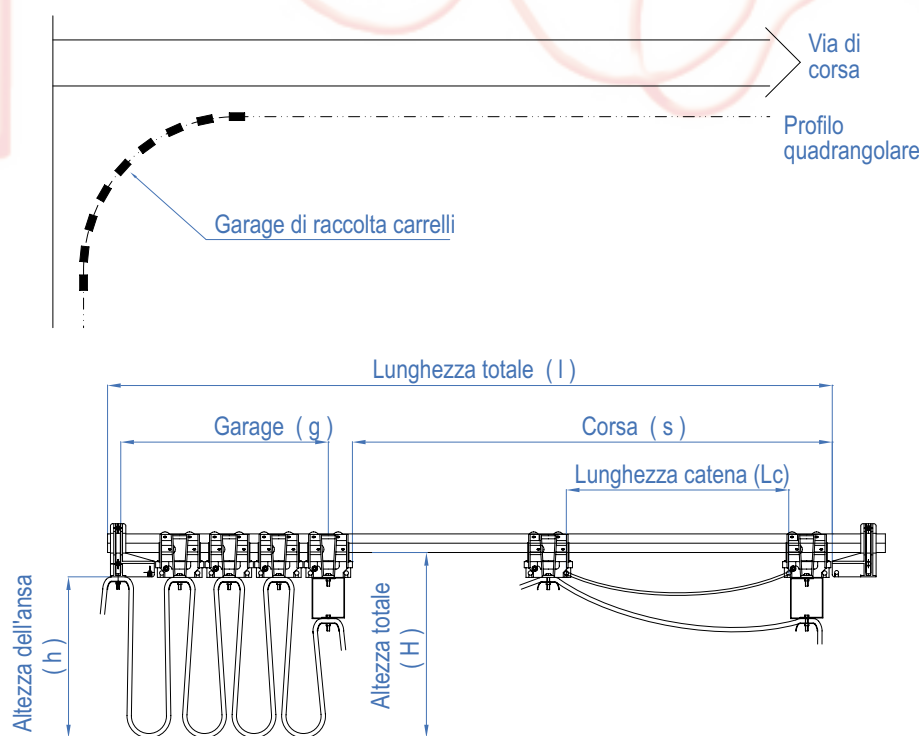



*By* CARPEL<sup>®</sup>  srl

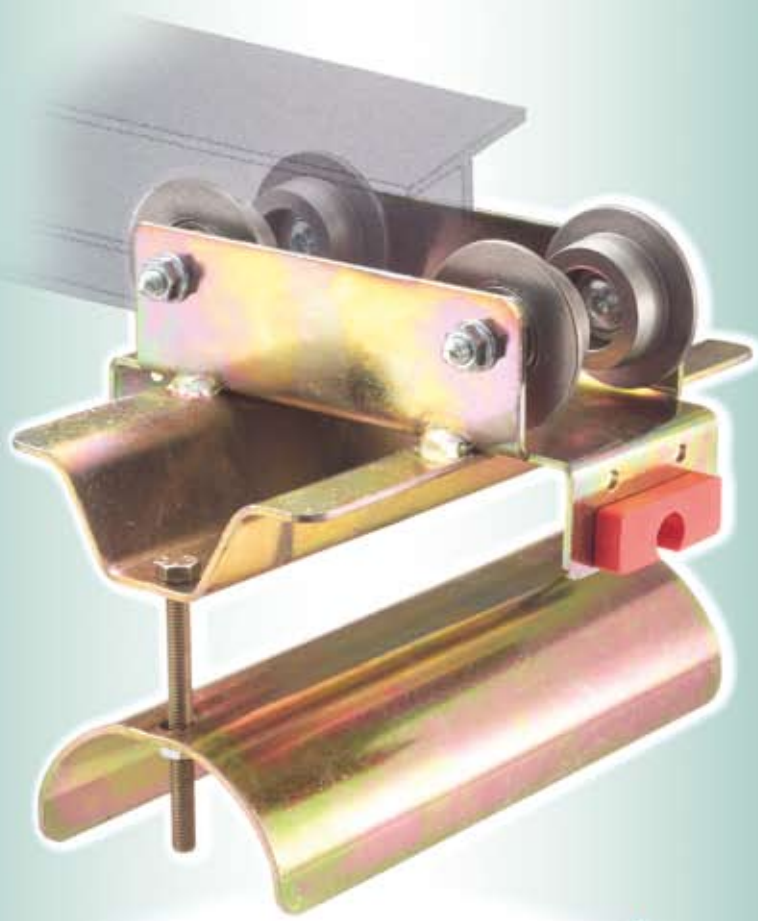

## CARRELLI PER TRAVI

### TROLLEYS FOR BEAMS

La By Carpel vi offre in questo catalogo una vasta scelta tra carrelli portacavo per travi IPE-NP particolarmente adatti per la distribuzione di energia, sia essa elettrica, pneumatica o altro, per apparecchi mobili quali: gru, carriponte, impianti galvanici, etc.

Potrete scegliere tra più serie di carrelli, suddivisi in base alla portata:

- Carrelli in acciaio per portate fino a 40 kg
- Carrelli in acciaio per portate fino a 60 Kg
- Carrelli in acciaio per portate fino a 150 Kg

Qualunque sia la scelta operata, sarà una scelta di qualità e sicurezza in quanto su tutti i prodotti troverete apposto il marchio "CE" a garanzia che la nostra produzione risponde ai requisiti dettati dalla Direttiva Macchine 89/932 e successivi emendamenti. Infatti tutti i nostri prodotti sono stati studiati e riveduti in modo da eliminare, dove possibile, tutti i possibili rischi derivanti dall'installazione, uso e dismissione degli stessi.

*By Carpel offers in this catalogue a wide range of cable carrying trolleys for IPE-NP beams that are particularly suitable for distributing electrical, pneumatic and other energies to mobile equipment as cranes, overhead traveling cranes, galvanic plants, etc.*

*Various trolley sets can be chosen, according to the required capacity:*

- *Steel trolleys for capacities up to 40 kg*
- *Steel trolleys for capacities up to 60 kg*
- *Steel trolleys for capacities up to 150 kg*

*Regardless of your choice, it will assure you quality and safety as all our products have been labelled with "CE" mark, to guarantee that our products meet the 89/932/EEC Machinery Directive and further amendments. All our products have been designed and reviewed aiming at eliminating, where possible, all the possible risks due to the product installation, use and dismantling.*

**By CARPEL**®  
srl



Ci riserviamo la facoltà di apportare, senza alcun preavviso, modifiche costruttive al fine di migliorare le qualità tecniche, funzionali ed estetiche del prodotto.

*We reserve the right to make modifications in order to improve the technical, functional and aesthetic qualities of our products without any prior notice.*



AZIENDA CON SISTEMA QUALITÀ  
CERTIFICATO DA DNV  
=UNI EN ISO 9001/2000=

## CARRELLI PER TRAVI

TROLLEYS FOR BEAMS

### Serie 4

#### Testata semplice

Simple head

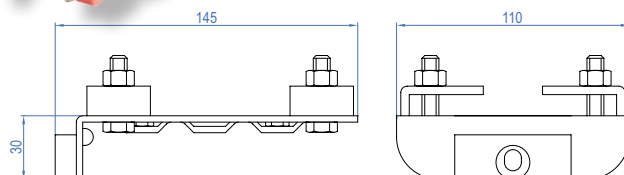
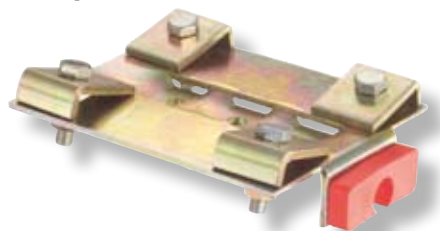

Materiale/Material	Acciaio zincato/Galvanized steel
	Acciaio inox/Stainless steel
Travi/Beams IPE-NP	da/from 80 a/to 140

<b>Articolo/Item</b>	<b>1400</b>
Peso/Weight	590 g

#### Testata con sella

Head with saddle

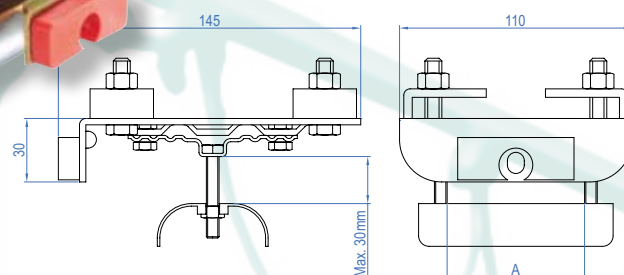

Materiale/Material	Acciaio zincato/Galvanized steel
	Acciaio inox/Stainless steel (solo per sella/only for saddle A=65)
Travi/Beams IPE-NP	da/from 80 a/to 140

Portata/Capacity	30 kg	
<b>Sella/Saddle</b>	<b>Peso/Weight</b>	<b>Articolo/Item</b>
A= 25 mm	670 g	<b>1401</b>
A= 35 mm	695 g	<b>1402</b>
A= 55 mm	720 g	<b>1403</b>
A= 65 mm	735 g	<b>1404</b>
A= 80 mm	755 g	<b>1405</b>
A= 100 mm	775 g	<b>1406</b>
A= 150 mm	1320 g	<b>1407</b>

#### Carrello portacavi

Cable carrying trolley

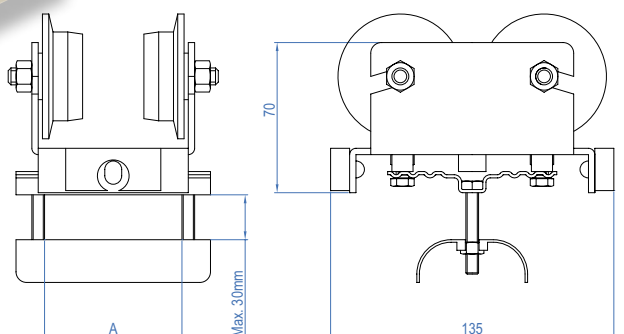
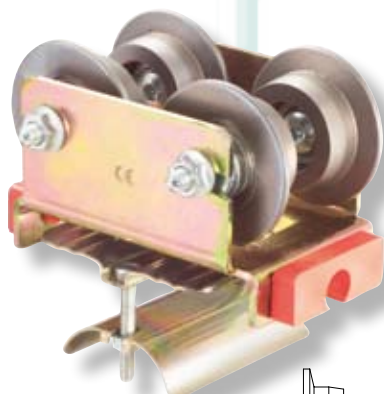

Materiale/Material	Acciaio zincato/Galvanized steel
	Acciaio inox/Stainless steel (solo per sella/only for saddle A=65)
Travi/Beams IPE-NP	da/from 80 a/to 140

<b>Ruote Nylon / Nylon wheels</b>	Ø 40 mm	
Portata/Capacity	25 kg	
<b>Ruote Nylon con cuscinetto / Nylon wheels with bearing</b>	Ø 40 mm	
Portata/Capacity	30 kg	
<b>Sella/Saddle</b>	<b>Peso/Weight</b>	<b>Articolo/Item</b>
A= 25 mm	845 g	<b>1421</b>
A= 35 mm	870 g	<b>1422</b>
A= 55 mm	895 g	<b>1423</b>
A= 65 mm	910 g	<b>1424</b>
A= 80 mm	930 g	<b>1425</b>
A= 100 mm	950 g	<b>1426</b>
A= 150 mm	1495 g	<b>1427</b>
<b>Ruote acciaio con cuscinetto / Steel wheels with bearing</b>	Ø 40 mm	
Portata/Capacity	40 kg	
<b>Sella/Saddle</b>	<b>Peso/Weight</b>	<b>Articolo/Item</b>
A= 25 mm	1305 g	<b>1451</b>
A= 35 mm	1330 g	<b>1452</b>
A= 55 mm	1355 g	<b>1453</b>
A= 65 mm	1370 g	<b>1454</b>
A= 80 mm	1390 g	<b>1455</b>
A= 100 mm	1410 g	<b>1456</b>
A= 150 mm	1955 g	<b>1457</b>

**Traino**  
Trailer

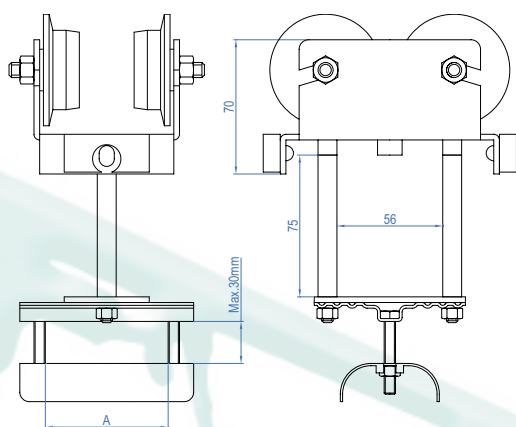

Materiale/Material	Acciaio zincato/Galvanized steel
Acciaio inox/Stainless steel (solo per sella/only for saddle A=65)	
Travi/Beams IPE-NP	da/from 80 a/to 140

Ruote Nylon/Nylon wheels	Ø 40 mm
Portata/Capacity	15 kg

Ruote Nylon con cuscinetto/Nylon wheels with bearing	Ø 40 mm
Portata/Capacity	20 kg

Sella/Saddle	Peso/Weight	Articolo/Item
A= 25 mm	1225 g	<b>1431</b>
A= 35 mm	1250 g	<b>1432</b>
A= 55 mm	1275 g	<b>1433</b>
A= 65 mm	1290 g	<b>1434</b>
A= 80 mm	1310 g	<b>1435</b>
A= 100 mm	1330 g	<b>1436</b>
A= 150 mm	1875 g	<b>1437</b>

Ruote Acciaio con cuscinetto/Steel wheels with bearing	Ø 40 mm
Portata/Capacity	30 kg

Sella/Saddle	Peso/Weight	Articolo/Item
A= 25 mm	1685 g	<b>1441</b>
A= 35 mm	1710 g	<b>1442</b>
A= 55 mm	1735 g	<b>1443</b>
A= 65 mm	1750 g	<b>1444</b>
A= 80 mm	1770 g	<b>1445</b>
A= 100 mm	1790 g	<b>1446</b>
A= 150 mm	2335 g	<b>1447</b>

**Traino speciale**  
Special trailer

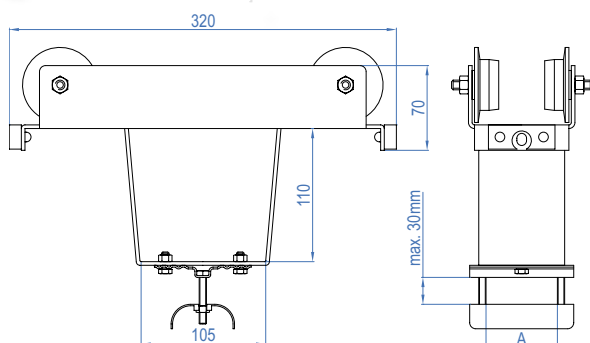

Materiale/Material	Acciaio zincato/Galvanized steel
Acciaio inox/Stainless steel (solo per sella/only for saddle A=65)	
Travi/Beams IPE-NP	da/from 80 a/to 140

Ruote Nylon/Nylon wheels	Ø 40 mm
Portata/Capacity	15 kg

Ruote Nylon con cuscinetto/Nylon wheels with bearing	Ø 40 mm
Portata/Capacity	20 kg

Sella/Saddle	Peso/Weight	Articolo/Item
A= 25 mm	2240 g	<b>1461</b>
A= 35 mm	2265 g	<b>1462</b>
A= 55 mm	2290 g	<b>1463</b>
A= 65 mm	2305 g	<b>1464</b>
A= 80 mm	2325 g	<b>1465</b>
A= 100 mm	2345 g	<b>1466</b>
A= 150 mm	2890 g	<b>1467</b>

Ruote Acciaio con cuscinetto/Steel wheels with bearing	Ø 40 mm
Portata/Capacity	30 kg

Sella/Saddle	Peso/Weight	Articolo/Item
A= 25 mm	2700 g	<b>1471</b>
A= 35 mm	2725 g	<b>1472</b>
A= 55 mm	2750 g	<b>1473</b>
A= 65 mm	2765 g	<b>1474</b>
A= 80 mm	2785 g	<b>1475</b>
A= 100 mm	2805 g	<b>1476</b>
A= 150 mm	3350 g	<b>1477</b>

**Serie 6**

**Testata semplice**  
Simple head

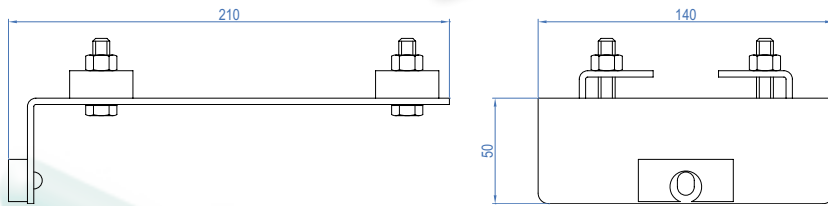
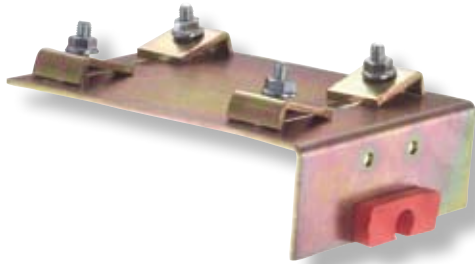

Materiale/Material Acciaio zincato o inox/ Galvanized or stainless Steel  
Travi/Beams IPE-NP da/ from 80 a/ to 140

<b>Articolo/Item</b>	<b>1600</b>
Peso/Weight	1115 g

**Testata con sella**  
Head with saddle

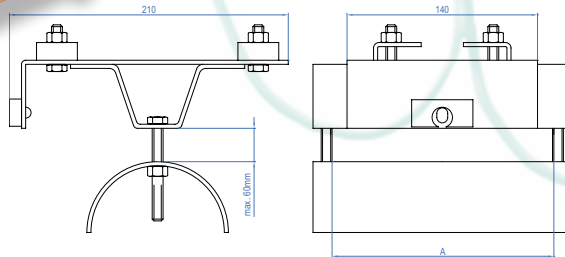
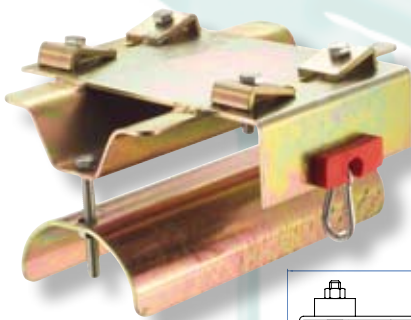

Materiale/Material Acciaio zincato o inox/ Galvanized or stainless Steel  
Portata/Capacity 50 kg  
Travi/Beams IPE-NP da/ from 80 a/ to 140

Sella/Saddle	Peso/Weight	Articolo/Item
A= 150 mm	2120 g	<b>1601</b>
A= 200 mm	2500 g	<b>1602</b>
A= 300 mm	3260 g	<b>1603</b>

**Carrello portacavi**  
Cable carrying trolley

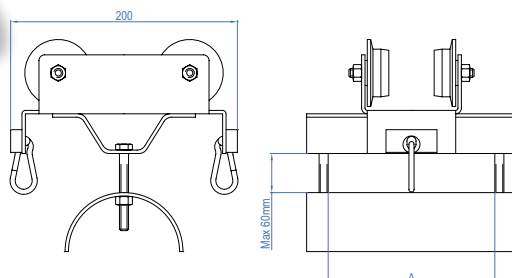
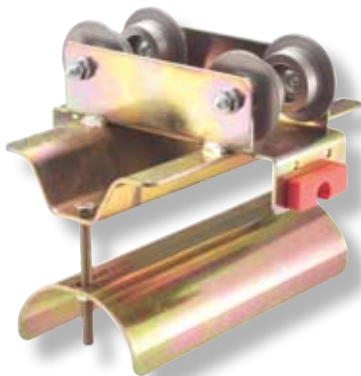

Materiale/Material Acciaio zincato o inox/ Galvanized or stainless Steel  
Ruote/Wheels Acciaio con cuscinetto/ Steel with bearing Ø 40  
Portata/Capacity 60 kg  
Travi/Beams IPE-NP da/ from 80 a/ to 140

Sella/Saddle	Peso/Weight	Articolo/Item
A= 150 mm	3020 g	<b>1651</b>
A= 200 mm	3400 g	<b>1652</b>
A= 300 mm	4160 g	<b>1653</b>

**Traino**  
Trailer

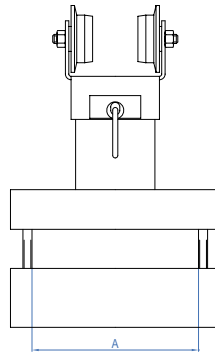
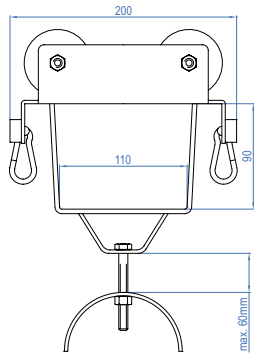
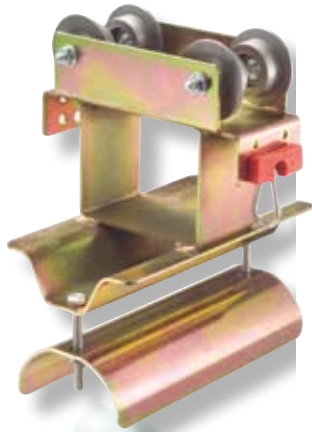

Materiale/Material	Acciaio zincato o inox/Galvanized or stainless Steel
Ruote/Wheels	Acciaio con cuscinetto/Steel with bearing Ø 40
Portata/Capacity	50 kg
Travi/Beams IPE-NP	da/ from 80 a/ to 140

Sella/Saddle	Peso/Weight	Articolo/Item
A= 150 mm	3300 g	<b>1641</b>
A= 200 mm	3680 g	<b>1642</b>
A= 300 mm	4440 g	<b>1643</b>

**Traino speciale**  
Special trailer

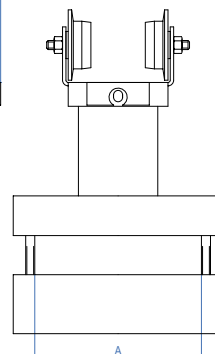
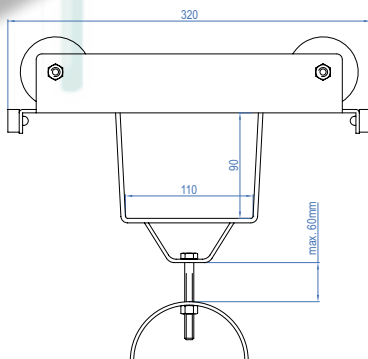
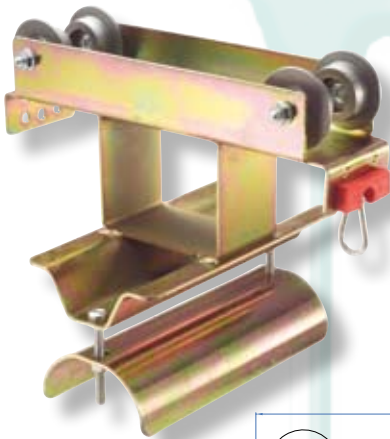

Materiale/Material	Acciaio zincato o inox/Galvanized or stainless Steel
Ruote/Wheels	Acciaio con cuscinetto/Steel with bearing Ø 40
Portata/Capacity	50 kg
Travi/Beams IPE-NP	da/ from 80 a/ to 140

Sella/Saddle	Peso/Weight	Articolo/Item
A= 150 mm	3785 g	<b>1661</b>
A= 200 mm	4165 g	<b>1662</b>
A= 300 mm	4825 g	<b>1663</b>



**Serie 7**

**Testata con sella**  
Head with saddle

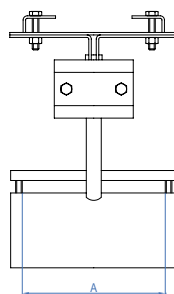
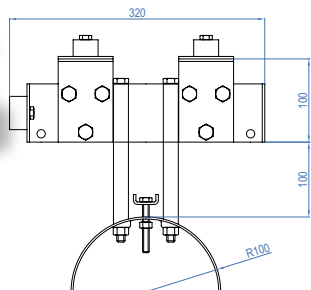

Materiale/Material	Acciaio zincato o inox/ Galvanized or stainless Steel
Portata/Capacity	150 kg
Travi/Beams IPE-NP	da/ from 80 a/ to 200

Sella/Saddle	Peso/Weight	Articolo/Item
A= 150 mm	4600 g	<b>1700/1</b>
A= 200 mm	4860 g	<b>1701/1</b>
A= 250 mm	5380 g	<b>1702/1</b>
A= 300 mm	5800 g	<b>1703/1</b>
A= 400 mm	6940 g	<b>1704/1</b>

**Carrello portacavi**  
Cable carrying trolley

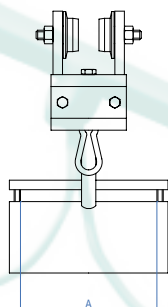
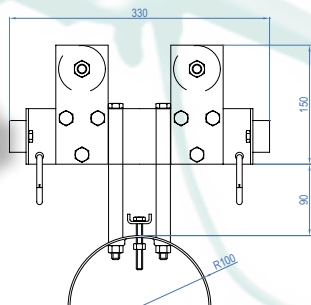

Materiale/Material	Acciaio zincato o inox/ Galvanized or stainless Steel
Ruote/Wheels	Acciaio con cuscinetto/Steel with bearing Ø 40-70
Portata/Capacity	150 kg
Travi/Beams IPE-NP	da/ from 80 a/ to 200

Sella/Saddle	Peso/Weight	Articolo/Item
A= 150 mm	5800 g	<b>1750/1</b>
A= 200 mm	6060 g	<b>1751/1</b>
A= 250 mm	6580 g	<b>1752/1</b>
A= 300 mm	7000 g	<b>1753/1</b>
A= 400 mm	7940 g	<b>1754/1</b>

**Traino**  
Trailer

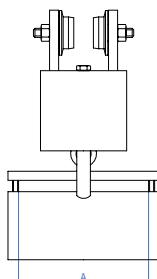
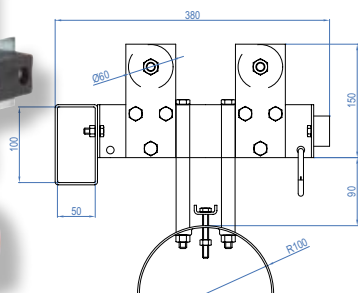
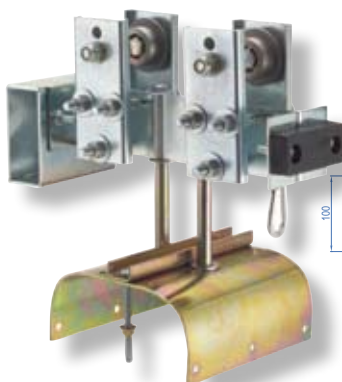

Materiale/Material	Acciaio zincato o inox/ Galvanized or stainless Steel
Ruote/Wheels	Acciaio con cuscinetto/Steel with bearing Ø 40-70
Portata/Capacity	130 kg
Travi/Beams IPE-NP	da/ from 80 a/ to 200

Sella/Saddle	Peso/Weight	Articolo/Item
A= 150 mm	6730 g	<b>1740/1</b>
A= 200 mm	6990 g	<b>1741/1</b>
A= 250 mm	7510 g	<b>1742/1</b>
A= 300 mm	7930 g	<b>1743/1</b>
A= 400 mm	8870 g	<b>1744/1</b>

**Testata con sella**  
Head with saddle

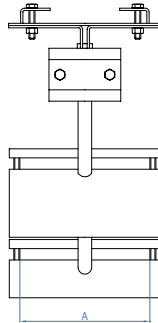
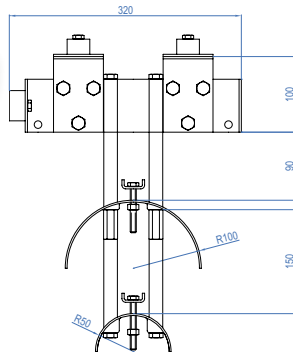

Materiale/Material	Acciaio zincato o inox/Galvanized or stainless Steel
Portata/Capacity	150 kg
Travi/Beams IPE-NP	dal/from 80 a/to 200

Sella/Saddle	Peso/Weight	Articolo/Item
A= 150 mm	4900 g	<b>1700/2</b>
A= 200 mm	5225 g	<b>1701/2</b>
A= 250 mm	5875 g	<b>1702/2</b>
A= 300 mm	6400 g	<b>1703/2</b>
A= 400 mm	7575 g	<b>1704/2</b>

**Carrello portacavi**  
Cable carrying trolley

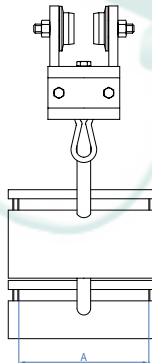
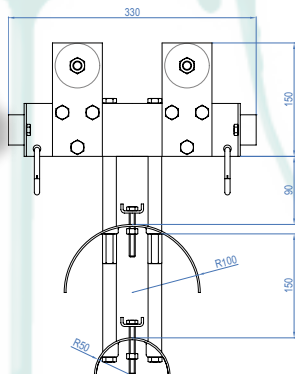

Materiale/Material	Acciaio zincato o inox/Galvanized or stainless Steel
Ruote/Wheels	Acciaio con cuscinetto/Steel with bearing Ø 40-70
Portata/Capacity	150 kg
Travi/Beams IPE-NP	dal/from 80 a/to 200

Sella/Saddle	Peso/Weight	Articolo/Item
A= 150 mm	6100 g	<b>1750/2</b>
A= 200 mm	6425 g	<b>1751/2</b>
A= 250 mm	7075 g	<b>1752/2</b>
A= 300 mm	7600 g	<b>1753/2</b>
A= 400 mm	8775 g	<b>1754/2</b>

**Traino**  
Trailer

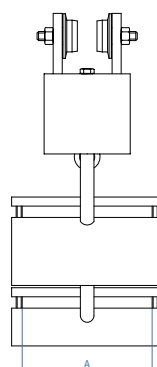
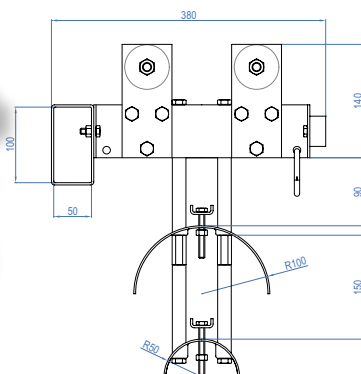

Materiale/Material	Acciaio zincato o inox/Galvanized or stainless Steel
Ruote/Wheels	Acciaio con cuscinetto/Steel with bearing Ø 40-70
Portata/Capacity	130 kg
Travi/Beams IPE-NP	dal/from 80 a/to 200

Sella/Saddle	Peso/Weight	Articolo/Item
A= 150 mm	7030 g	<b>1740/2</b>
A= 200 mm	7355 g	<b>1741/2</b>
A= 250 mm	8000 g	<b>1742/2</b>
A= 300 mm	8530 g	<b>1743/2</b>
A= 400 mm	9705 g	<b>1744/2</b>

**Connettore per cavo piatto - presa tipo CARPEL**  
Connector for flat cable - socket type CARPEL

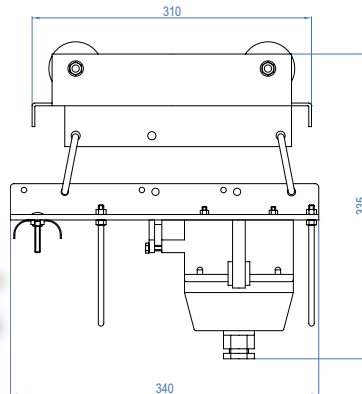

Materiale/Material	Acciaio zincato o inox/ Galvanized or stainless Steel
Preso in nylon/Nylon socket	
Ruote/Wheels	Acciaio con cuscinetto/Steel with bearing Ø 40
Portata/Capacity	60 kg
Travi/Beams IPE-NP	da/ from 80 a/ to 140
Peso/Weight	4310 kg

Articolo/Item	5060	5061	5062
	10 Poli/Pole	16 Poli/Pole	24 Poli/Pole

**Connettore per cavo piatto - presa tipo STANDARD**  
Connector for flat cable - socket type STANDARD

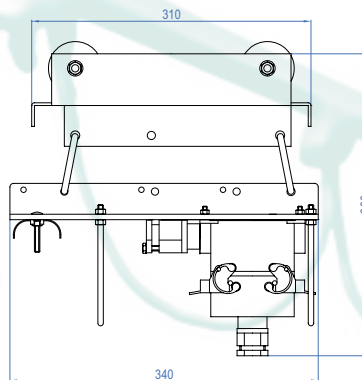
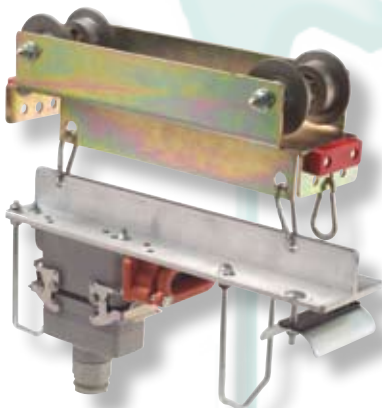

Materiale/Material	Acciaio zincato o inox/ Galvanized or stainless Steel
Preso in alluminio/Aluminium socket	
Ruote/Wheels	Acciaio con cuscinetto/Steel with bearing Ø 40
Portata/Capacity	60 kg
Travi/Beams IPE-NP	da/ from 80 a/ to 140
Peso/Weight	4295 kg

Articolo/Item	3039	3040	3041	3042
	10 Poli/Pole	16 Poli/Pole	24 Poli/Pole	32 Poli/Pole

**Connettore per cavo tondo - presa tipo STANDARD**  
Connector for round cable - socket type STANDARD

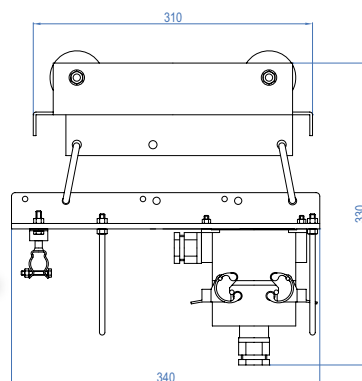
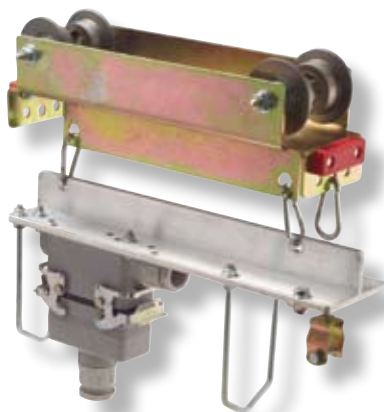

Materiale/Material	Acciaio zincato o inox/ Galvanized or stainless Steel
Preso in alluminio/Aluminium socket	
Ruote/Wheels	Acciaio con cuscinetto/Steel with bearing Ø 40
Portata/Capacity	60 kg
Travi/Beams IPE-NP	da/ from 80 a/ to 140
Peso/Weight	4070 kg

Articolo/Item	4049	4050	4051	4052
	10 Poli/Pole	16 Poli/Pole	24 Poli/Pole	32 Poli/Pole

**ISTRUZIONI DI MONTAGGIO - linea con traino -**  
**ASSEMBLY INSTRUCTIONS - line with trailer -**

- 1- Inserire la prima testata (senza sella) dalla parte opposta alla scatola di alimentazione, verificando che il tampone in PVC sia rivolto verso l'interno della linea.
- 2- Fissare la testata alla trave serrando le 4 viti delle staffe a "L".
- 3- Inserire il traino sulla trave dall'estremità senza testata.
- NOTA: nel caso della serie 7, il traino non è simmetrico ed è quindi necessario verificare che il tampone in PVC sia rivolto verso l'interno della linea.
- 4- Inserire uno dopo l'altro tutti i carrelli sulla trave.
- 5- Inserire la seconda testata e fissarla, per mezzo delle 4 viti delle staffe a "L", all'estremità libera della trave verificando che il tampone in PVC sia rivolto verso l'interno della linea.
- 6- Inserire il cavo di alimentazione tra sella e controsella, partendo dalla testata dalla parte della scatola di alimentazione, arrivando fino al traino, passando per tutti i carrelli.
- 7- Lasciare alle due estremità della linea (prima della testata e dopo il traino) sufficiente cavo per raggiungere la scatola di alimentazione e l'utilizzatore. Tra carrello e carrello lasciare il cavo necessario per ottenere l'ansa desiderata.
- 8- Fissare il cavo a tutti gli elementi della linea, serrando le viti delle relative selle.

- 1- Insert the first head (without saddle) from the supply box opposite side, paying attention so as the PVC plug is pointing towards the line inside.
- 2- Tighten the 4 screws of the "L" shaped stirrups to fix the head to the beam.
- 3- Insert the trailer into the beam from the headless end.
- REMARK: as to series 7, the trailer is not symmetrical and it is therefore necessary to make sure the PVC plug is pointing towards the line inside.
- 4- Insert all the trolleys into the beam, one after the other.
- 5- Insert the second head and tighten the 4 screws of the "L" shaped stirrups to fix it to the beam free end, making sure the PVC plug is pointing towards the line inside.
- 6- Run the feeding cable between the saddle and the countersaddle, starting from the head at the supply box side, passing through all the trolleys and ending at the trailer.
- 7- Make sure to leave enough cable length at the two line ends (before the head and after the trailer) to reach the supply box and the user. Leave enough cable length between each trolley to get the required loop.
- 8- Tighten the relevant saddle screws to fix the cable to all the line elements.

**Misure normalizzate delle travi IPE - NP**  
**Normalised measures of IPE - NP beams**

Al momento dell'ordine specificare la misura della trave lungo la quale devono scorrere i carrelli: Se si tratta di una trave normalizzata comunicare tipo e la dimensione; se invece la trave non è normalizzata o non rientra in quelle elencate di seguito, è necessario comunicare la larghezza dell'ala e il suo spessore.  
When placing your order, specify the measure of the beam where the trolleys will slide. For standardized beams, please advise the type and the dimension. For non-standardized beams or for beams not being included in the tables here below, it is important to advise the flange width and thickness.

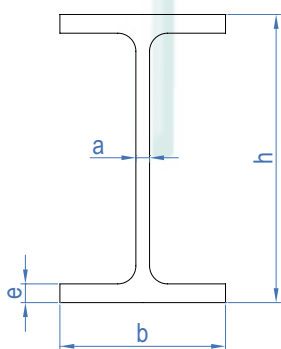

Travi/Beams IPE

h (mm)	b(mm)	a (mm)	e (mm)
80	46	3,8	5,2
100	55	4,1	5,7
120	64	4,4	6,3
140	73	4,7	6,9
160	82	5,0	7,4
180	91	5,3	8,0
200	100	5,6	8,5
220	110	5,9	9,2
240	120	6,2	9,8
270	135	6,6	10,2
300	150	7,1	10,7

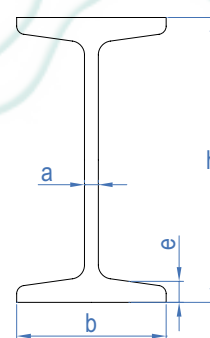

Travi/Beams NP

h (mm)	b(mm)	a (mm)	e (mm)
80	42	3,9	5,8
100	50	4,5	6,6
120	58	5,1	7,5
140	66	5,7	8,4
160	74	6,3	9,3
180	82	6,9	10,2
200	90	7,5	11,0
220	98	8,1	11,9
240	106	8,7	12,8
260	113	9,4	13,8
300	119	10,1	14,8

*By* CARPEL<sup>®</sup> srl 

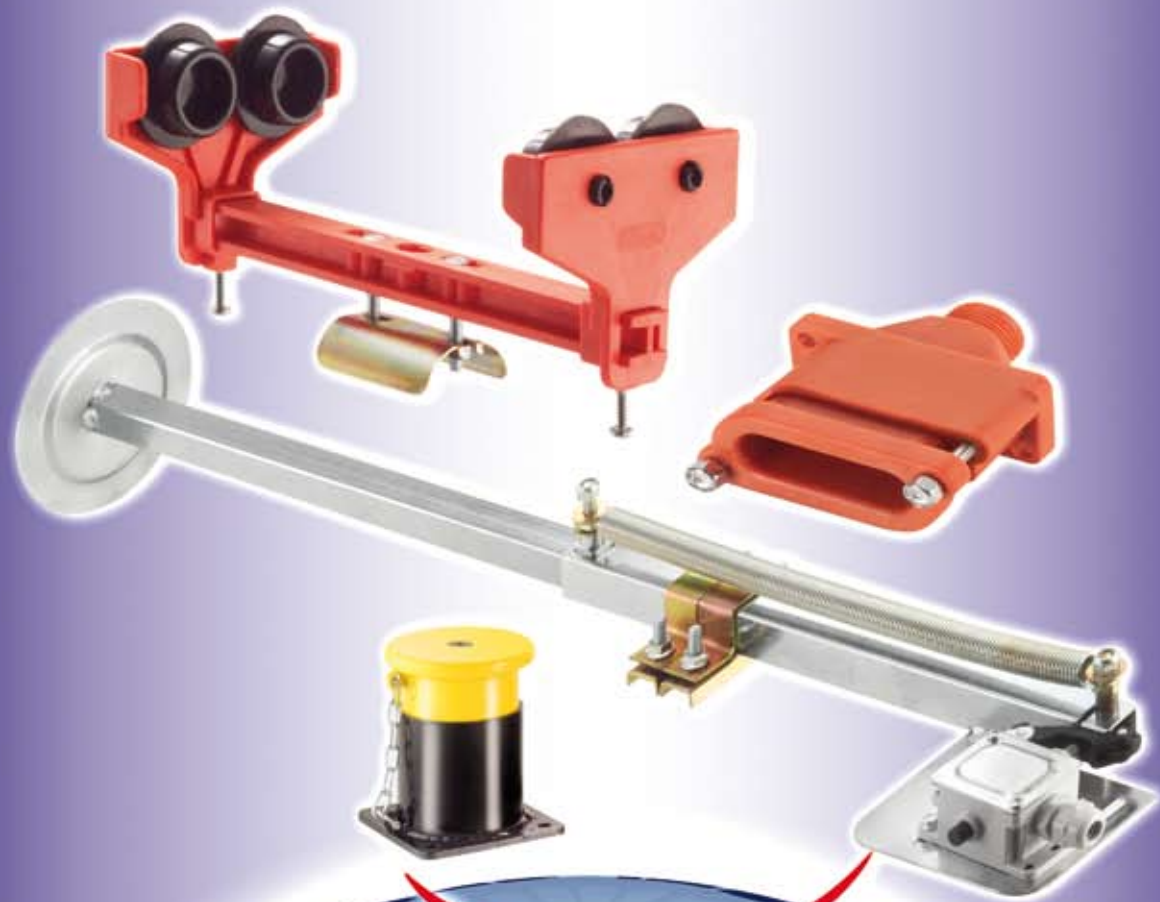

**CARRELLI PER FUNE**  
**CARRELLI REGOLABILI E ACCESSORI**  
TROLLEYS FOR ROPES, ADJUSTABLE TROLLEYS  
AND ACCESSORIES



Ci riserviamo la facoltà di apportare, senza alcun preavviso, modifiche costruttive al fine di migliorare le qualità tecniche, funzionali ed estetiche del prodotto.

*We reserve the right to make modifications in order to improve the technical, functional and aesthetical qualities of our products without any prior notice.*



AZIENDA CON SISTEMA QUALITÀ  
CERTIFICATO DA DNV  
**=UNI EN ISO 9001/2000=**

## CARRELLI PER FUNE CARRELLI REGOLABILI E ACCESSORI

TROLLEYS FOR ROPES, ADJUSTABLE TROLLEYS AND ACCESSORIES



### Carrello per fune - a 1 ruota nylon Trolley for ropes - with 1 nylon wheel

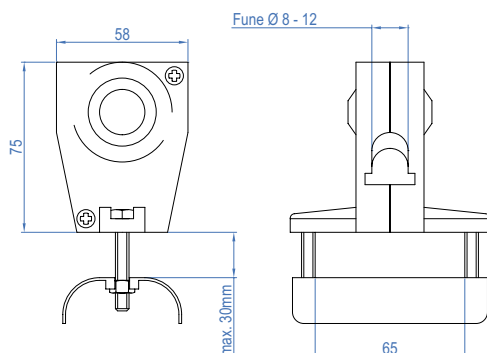

Materiale/Material	Corpo in nylon/Nylon body
	Minuteria in acciaio zincato/Small parts in galvanized steel
Ruote/Wheels	Ø 45 mm in nylon
Portata/Capacity	10 kg
Peso/Weight	180 g

<b>Articolo/Item</b>	<b>1304</b>
Codice/Code	CRFU 65N1

### Carrello per fune - a 2 ruote nylon Trolley for ropes - with 2 nylon wheels

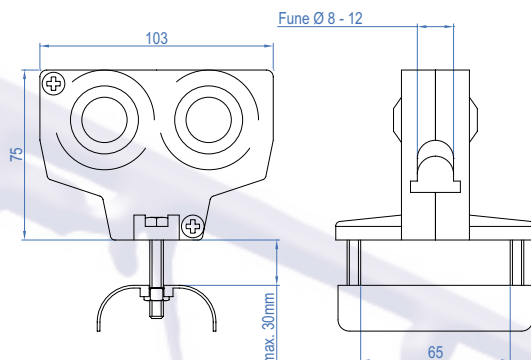

Materiale/Material	Corpo in nylon/Nylon body
	Minuteria in acciaio zincato/Small parts in galvanized steel
Ruote/Wheels	Ø 45 mm in nylon
Portata/Capacity	15 kg
Peso/Weight	220 g

<b>Articolo/Item</b>	<b>1324</b>
Codice/Code	CRFU 65N2

### Carrello per fune Trolley for ropes

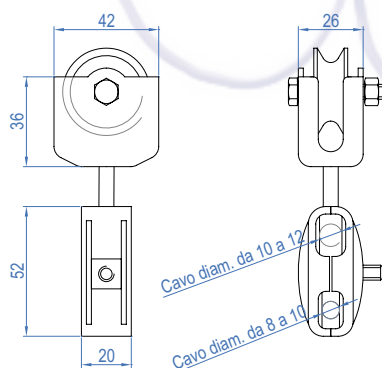

Materiale/Material	Corpo in nylon/Nylon body
	Minuteria in acciaio zincato/Small parts in galvanized steel
Ruote/Wheels	Ø 45 mm in nylon
Portata/Capacity	10 kg
Peso/Weight	15 g

<b>Articolo/Item</b>	<b>1314</b>
Codice/Code	CRFU T20N1

### Carrello per fune - a 2 ruote cuscinetto Trolley for ropes - with 2 wheels with bearing

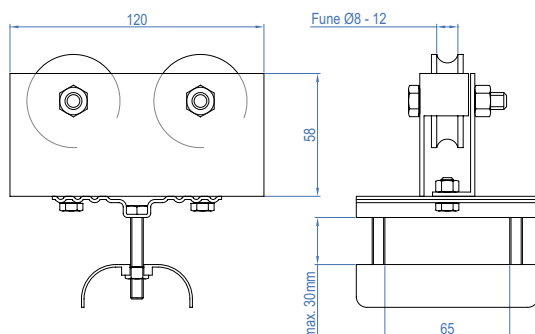
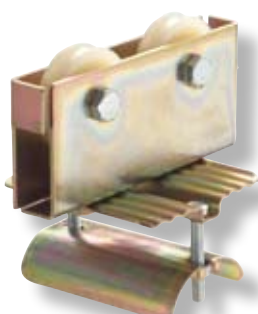

Materiale/Material	Acciaio zincato/Galvanized steel
Ruote/Wheels	Ø 45 mm in nylon
Portata/Capacity	20 kg
Peso/Weight	570 g

<b>Articolo/Item</b>	<b>1344</b>
Codice/Code	CFA 65NC2

# CARRELLI PER FUNE CARRELLI REGOLABILI E ACCESSORI

TROLLEYS FOR ROPES, ADJUSTABLE TROLLEYS AND ACCESSORIES



## Testata regolabile

Adjustable head

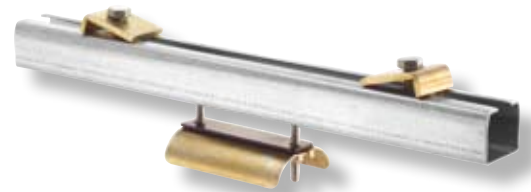
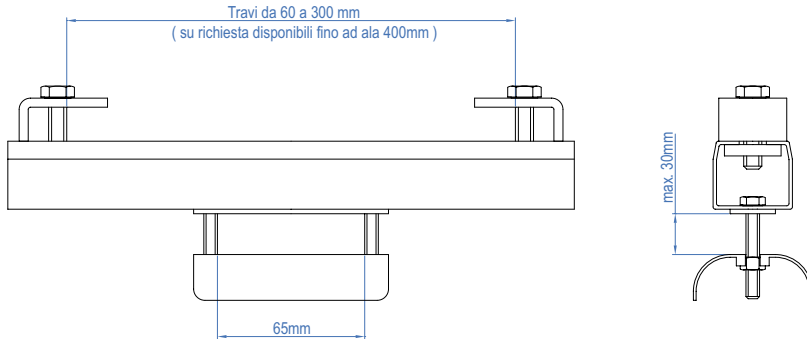

Materiale/Material	Acciaio zincato/Galvanized steel
Portata/Capacity	20 kg
Peso/Weight	560 g

Articolo/Item	<b>021</b>
Codice/Code	TES REG 65

## Carrello regolabile a 2 ruote

Adjustable trolley with 2 wheels

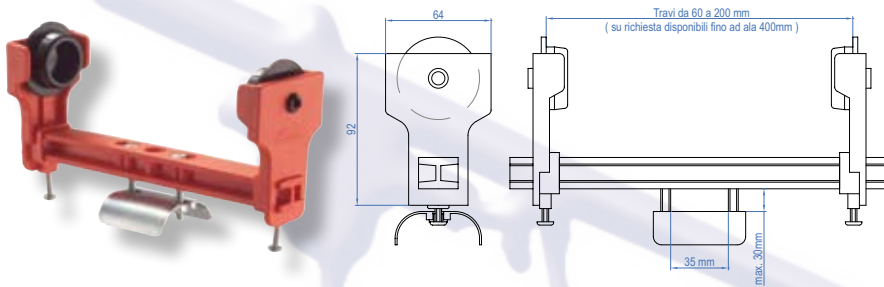

Materiale/Material	Corpo in nylon/Nylon body
	Minuteria in acciaio zincato/Small parts in galvanized steel
	Ruote nylon Ruote acciaio con cuscinetto
	Nylon wheels Steel wheels with bearing
Portata/Capacity	5 kg 10 kg
Peso/Weight	240 g 580 g

Articolo/Item	<b>031</b>	<b>041</b>
Codice/Code	CRES 65 N2	CRES 65 C2

## Carrello regolabile a 4 ruote

Adjustable trolley with 4 wheels

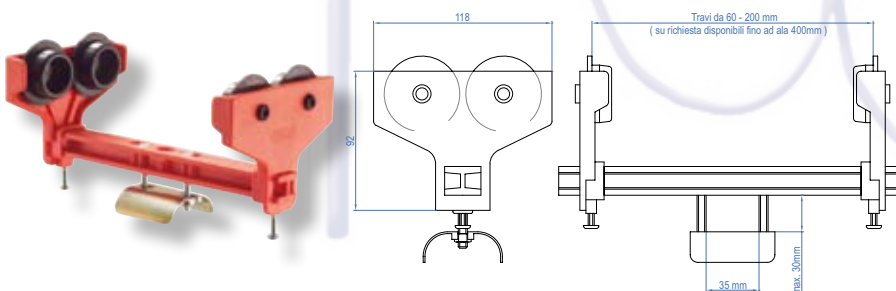

Materiale/Material	Corpo in nylon/Nylon body
	Minuteria in acciaio zincato/Small parts in galvanized steel
	Ruote nylon/Nylon wheels
Portata/Capacity	10 kg
Peso/Weight	300 g

Articolo/Item	<b>071</b>
Codice/Code	CRES 65 N4

## Carrello regolabile

Adjustable trolley

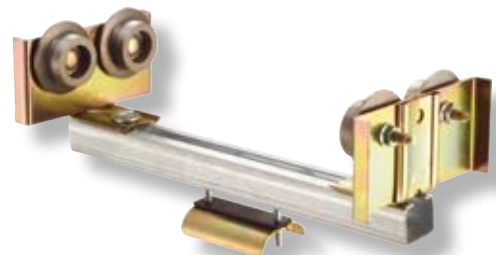
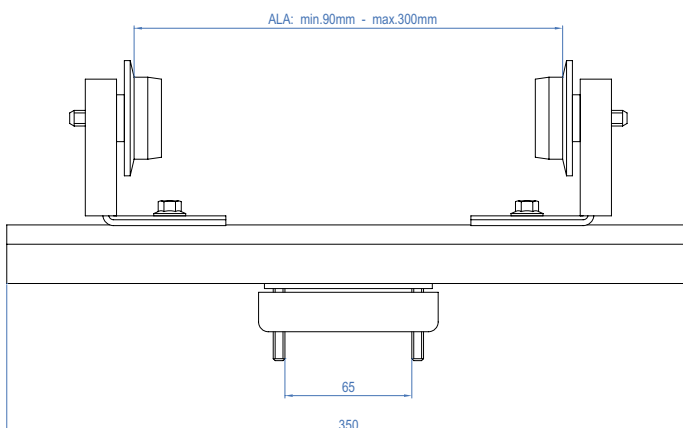

Materiale/Materiale	Acciaio zincato/Galvanized steel
	Ruote acciaio con cuscinetto/Steel wheels with bearing
Portata/Capacity	15 kg
Peso/Weight	980 g

Articolo/Item	<b>081</b>
Codice/Code	CRES 65 C4



# CARRELLI PER FUNE CARRELLI REGOLABILI E ACCESSORI

TROLLEYS FOR ROPES, ADJUSTABLE TROLLEYS AND ACCESSORIES



## Respingenti

Bumpers

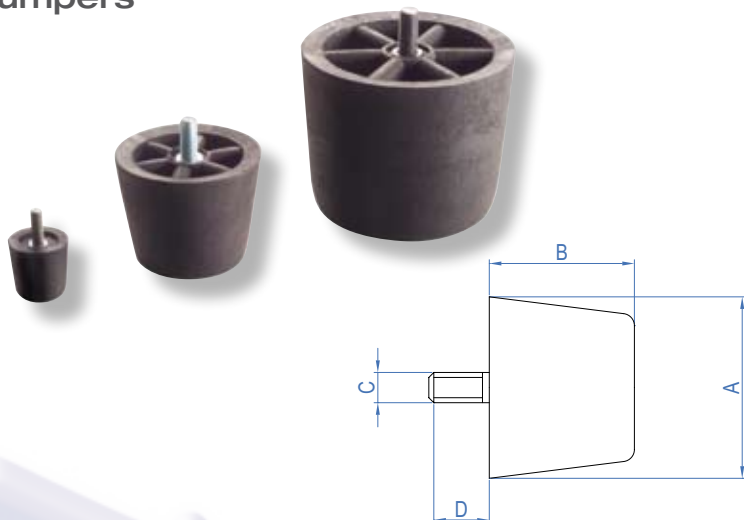

Codice/Code	Articolo/Item	A	B	C	D
RESPx4	<b>x4</b>	40	40	M8	25
RESPx6	<b>x6</b>	60	50	M10	25
RESPx8	<b>x8</b>	80	60	M12	25
RESPx10	<b>x10</b>	100	80	M12	25
RESPx12	<b>x12</b>	120	100	M14	30
RESPx15	<b>x15</b>	150	120	M14	30

## Tampone rettangolare

Rectangular plug

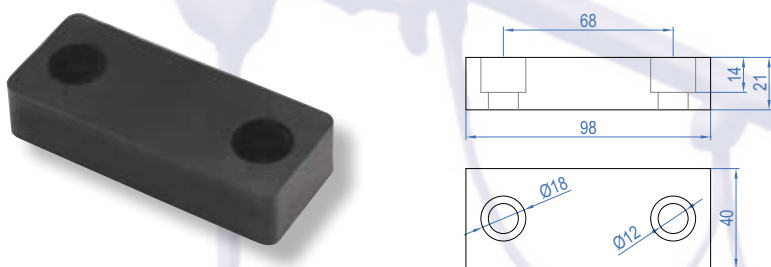

Materiale/Material	PVC speciale/Special PVC
Peso/Weight	105 g

**Articolo/Item** **3401**

## Tampone rettangolare raggato

Rectangular plug with radius

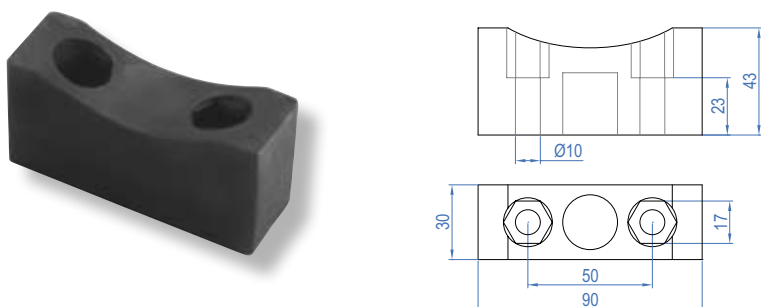

Materiale/Material	PVC speciale/Special PVC
Peso/Weight	125 g

**Articolo/Item** **3402**

**CARRELLI PER FUNE**  
**CARRELLI REGOLABILI E ACCESSORI**

TROLLEYS FOR ROPES, ADJUSTABLE TROLLEYS AND ACCESSORIES



**Pressacavo 80x25 per cavo piatto**

Cable gland 80x25 for flat cable

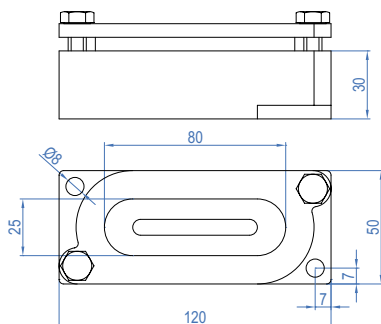

Materiale/ Material	Alluminio/ Aluminium
Peso/ Weight	340 g

**Articolo/ Item 3452**

**Pressacavo 55x18 per cavo piatto**

Cable gland 55x18 for flat cable

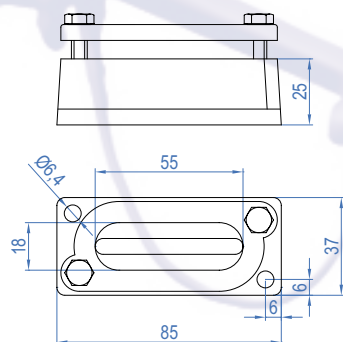

Materiale/ Material	Nylon	Alluminio/ Aluminium
Peso/ Weight	105 g	160 g

**Articolo/ Item 3450 3451**

**Pressacavo 55x18 con raccordo per attacco PG21**

Cable gland 55x18 with union for PG21 connection

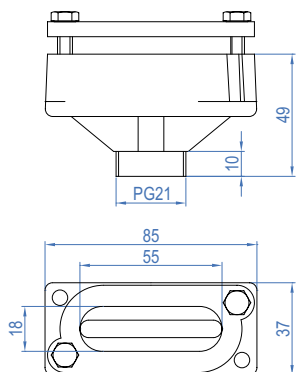

Materiale/ Material	Nylon
Peso/ Weight	120 g

**Articolo/ Item 3453**

## CARRELLI PER FUNE CARRELLI REGOLABILI E ACCESSORI

TROLLEYS FOR ROPES, ADJUSTABLE TROLLEYS AND ACCESSORIES



### Anticollisione con staffe

Anticollision device with stirrups

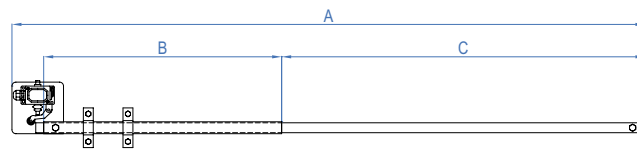
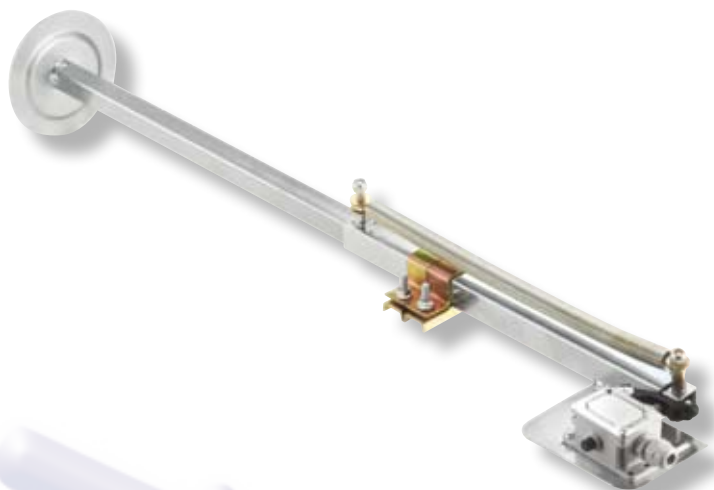

Codice/Code	A	B	C Corsa/Stroke	Articolo/Item
ANTI 500	970	400	500	3500
ANTI 800	1570	600	800	3501
ANTI 1200	2470	1200	1200	3502
ANTI 1350	2470	1050	1350	3503
ANTI 1250	2470	1200	1250	3504

### Anticollisione con ruote guida scorrimento

Anticollision device with sliding guide wheels

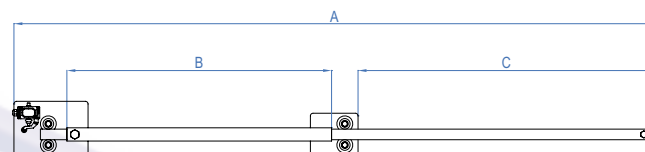
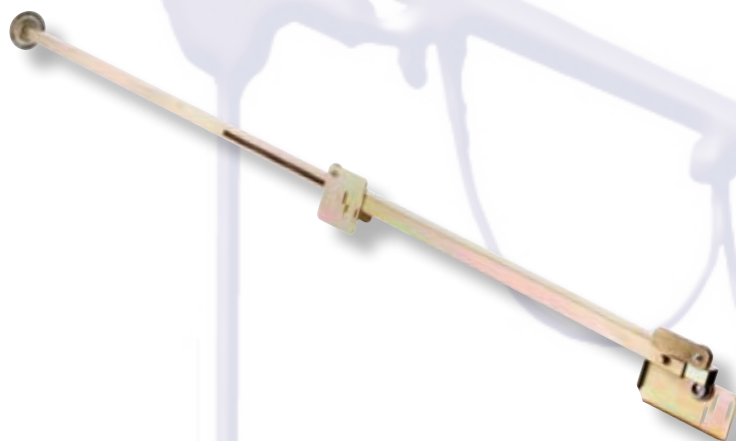

Codice/Code	A	B	C Corsa/Stroke	Articolo/Item
ANTI 1600	3150	1200	1600	3505
ANTI 2000	4150	1850	2000	3506
ANTI 2500	4650	1850	2500	3507

### Staffe per anticollisione

Stirrups for anticollision device

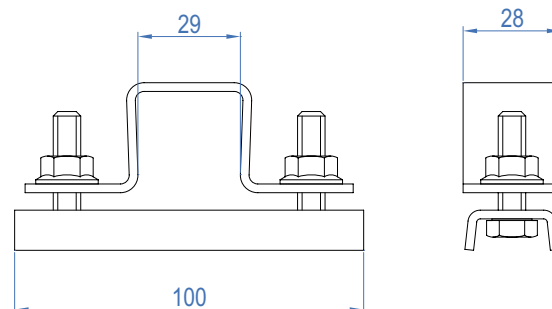
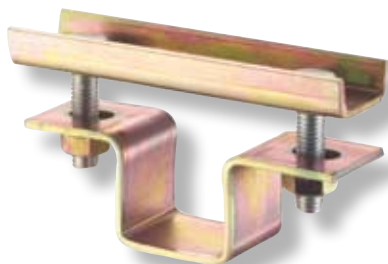

Materiale/Material Acciaio zincato/Galvanized Steel

Articolo/Item 3509

**Ruote nylon per travi**  
 Nylon wheels for beams

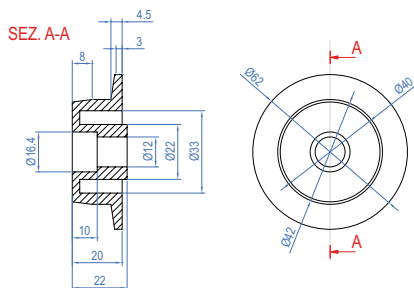

Materiale/Material Nylon

Articolo/Item 3700

**Ruote nylon con cuscinetto per travi**  
 Nylon wheels with bearing for beams

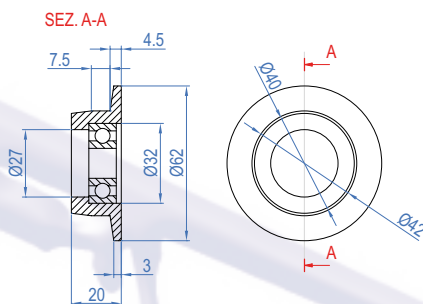

Materiale/Material Nylon

Articolo/Item 3701

**Ruote acciaio per travi**  
 Steel wheels for beams

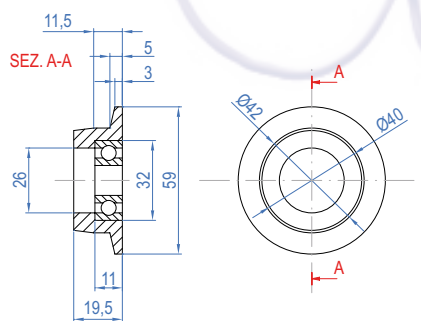

Materiale/Material Acciaio zincato/Galvanized Steel

Articolo/Item 3702

**Ruote acciaio per travi**  
 Steel wheels for beams

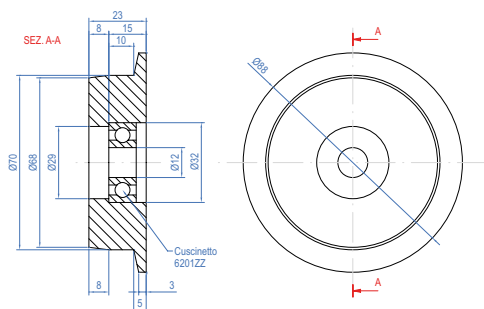

Materiale/Material Acciaio zincato/Galvanized Steel

Articolo/Item 3703

# CARRELLI PER FUNE CARRELLI REGOLABILI E ACCESSORI



TROLLEYS FOR ROPES, ADJUSTABLE TROLLEYS AND ACCESSORIES

## Mensola Bracket

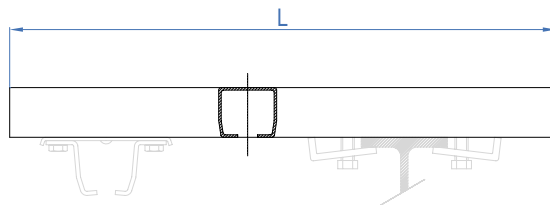

Materiale/Material	Acciaio zincato/Galvanized Steel				
	L=350mm	L=450mm	L=550mm	L=650mm	L=800mm
Peso/Weight	721 g	840 g	959 g	1078 g	1257 g
Portata/Capacity	35 kg	30 kg	25 kg	20 kg	15 kg

Articolo/Item	350	450	550	650	800
Codice/Code	MEN 1-350	MEN 1-450	MEN 1-550	MEN 1-650	MEN 1-800

## Staffe per bloccaggio su trave Stirrups for beam clamping

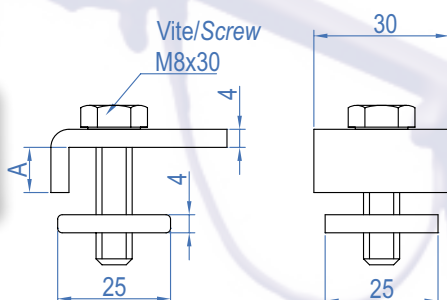

Materiale/Material	Acciaio zincato/Galvanized Steel			
	A=10mm	A=15mm	A=20mm	A=25mm
Peso/Weight	70 g	75 g	80 g	85 g
Portata/Capacity	50 kg			

Articolo/Item	1000	1001	1002	1003
Codice/Code	STA 1 L10	STA 1 L15	STA 1 L20	STA 1 L25

## Staffe curve Bent stirrups

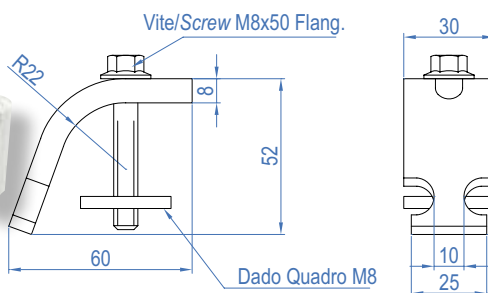

Materiale/Material	Acciaio zincato/Galvanized Steel
Peso/Weight	180 g
Portata/Capacity	50 kg

Articolo/Item	3602
Codice/Code	STAFFECURVE

**C-Rail speciale 35x50**

Special C-Rail 35x50

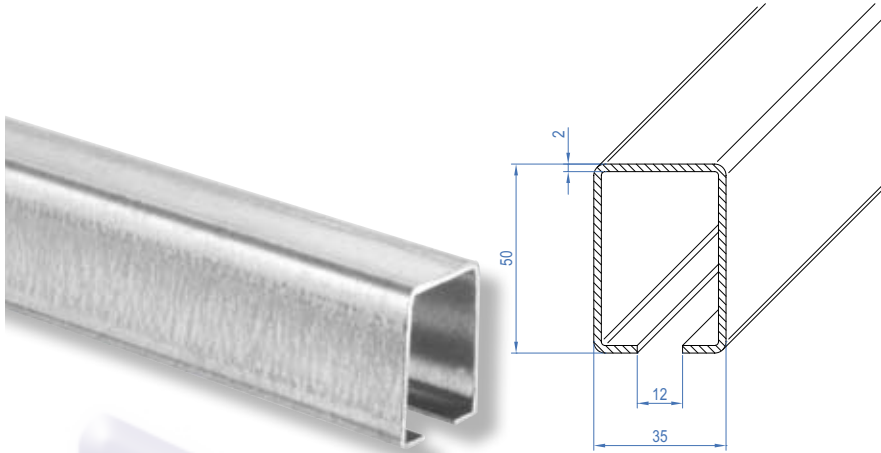

Materiale/Material	Acciaio zincato/Galvanized Steel
Peso/Weight	2,3 kg/m

**Articolo/Item** **CRAIL**

**Giunto bloccaggio tubo 40x40**

Blocking tube joint 40x40

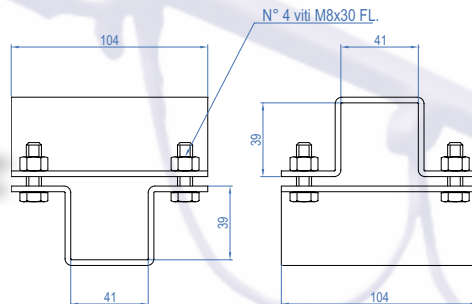

Materiale/Material	Acciaio zincato/Galvanized Steel
Peso/Weight	890 g

**Articolo/Item** **4101**

**Giunto bloccaggio tubo 50x50**

Blocking tube joint 50x50

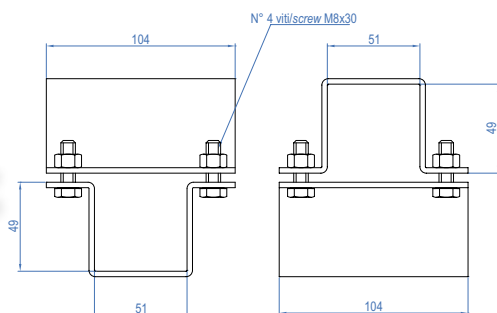

Materiale/Material	Acciaio zincato/Galvanized Steel
Peso/Weight	980 g

**Articolo/Item** **4102**

## CARRELLI PER FUNE CARRELLI REGOLABILI E ACCESSORI

TROLLEYS FOR ROPES, ADJUSTABLE TROLLEYS AND ACCESSORIES



### Custodia connettore con inserto a spina - tipo CARPEL

Connector case with plug insertion - type CARPEL



Materiale/Material Nylon

<b>Articolo/Item</b>	<b>3300</b>	<b>3302</b>
	16 Poli/Pole	24 Poli/Pole

### Custodia connettore con inserto a spina - tipo STANDARD

Connector case with plug insertion - type STANDARD



Materiale/Material Alluminio/Aluminium

<b>Articolo/Item</b>	<b>3301</b>	<b>3303</b>
	16 Poli/Pole	24 Poli/Pole

### Fungo portacavo

Cable carrying head

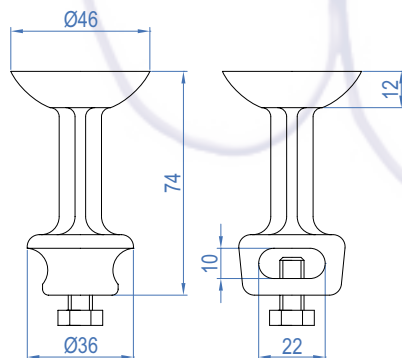

Materiale/Material Nylon  
Peso/Weight 25 g

<b>Articolo/Item</b>	<b>3454</b>
----------------------	-------------

### Ferma anse

Loop fastener



Materiale/Material Acciaio zincato/Galvanized Steel  
Lunghezza utile interna  
Internal working length 150 mm 200 mm 250 mm 300 mm 400 mm

<b>Articolo/Item</b>	<b>3800</b>	<b>3801</b>	<b>3802</b>	<b>3803</b>	<b>3804</b>
----------------------	-------------	-------------	-------------	-------------	-------------

## CARRELLI PER FUNE CARRELLI REGOLABILI E ACCESSORI

TROLLEYS FOR ROPES, ADJUSTABLE TROLLEYS AND ACCESSORIES

By CARPEL<sup>®</sup> 

### Catena Genovese

Chain genoa style



Materiale/Material Acciaio zincato/Galvanized Steel Inox

Articolo/Item 3306 3307

### Dadi quadrati

Square nuts

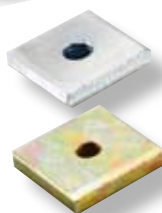

Materiale/Material Acciaio zincato/Galvanized Steel

M4 M5 M6 M8

Articolo/Item 3603 3604 3600 3601

### Moschettoni

Spring-clips



Materiale/Material Acciaio zincato/Galvanized Steel Inox

Articolo/Item 3304 3305

### Stecche per carrello portaconnettore

Slats for connector carrying trolley

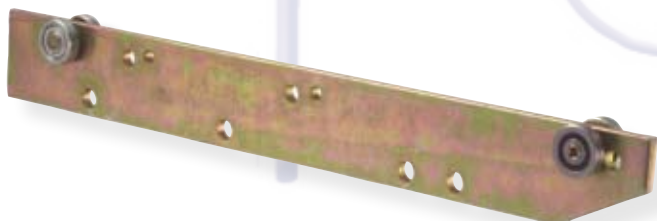

Materiale/Material Acciaio zincato/Galvanized Steel

Tipo/Type Tipo/Type

EUROPEO 2000

Ruote cusc./Wheels Bearing Ø 25 mm Ø 32 mm

Articolo/Item 3102 3202

### Carrello portaconnettore

Connector carrying trolley



Materiale/Material Corpo alluminio/Body aluminium

Minuteria in acciaio zincato/Small parts in galvanized steel

Tipo/Type Tipo/Type

EUROPEO 2000

Ruote cusc./Wheels Bearing Ø 25 mm Ø 32 mm

Articolo/Item 3101 3201



# CARRELLI PER FUNE CARRELLI REGOLABILI E ACCESSORI



TROLLEYS FOR ROPES, ADJUSTABLE TROLLEYS AND ACCESSORIES

## Respingenti ferro tipo -A- corsa singola Steel bumpers type -A- single stroke

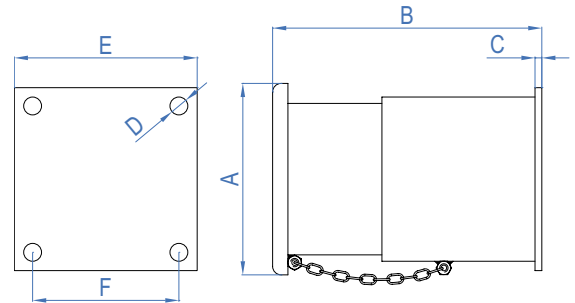

TIPO/TYPE	Forza ammortizzante Cushioning force [kg]	Corsa/Stroke [mm]	DIMENSIONI/DIMENSIONS					
			A	B	C	D	E	F
1.T	1000	40	120	158	6	11	130	100
2.T	2000	50	145	185	6	13	150	118
3.T	3000	60	175	230	7	15	170	134
5.T	5000	70	190	260	7	17	185	150
7.T	7000	75	200	290	8	19	200	162
10.T	10000	85	225	310	8	21	215	172
15.T	15000	95	250	365	10	23	260	212
20.T	20000	100	290	420	10	25	300	240
30.T	30000	110	305	465	12	25	330	263
40.T	40000	120	320	512	14	28	330	263
50.T	50000	130	350	545	16	28	350	278

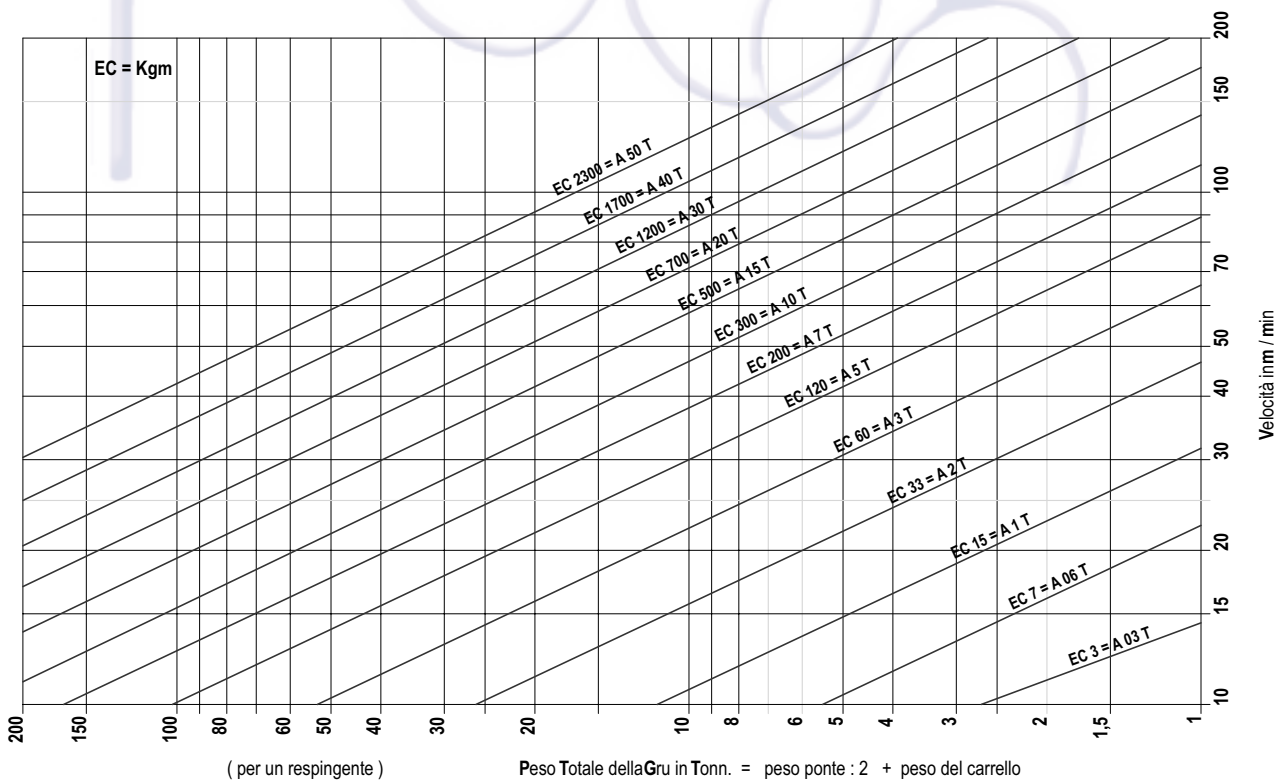

# CARRELLI PER FUNE CARRELLI REGOLABILI E ACCESSORI



TROLLEYS FOR ROPES, ADJUSTABLE TROLLEYS AND ACCESSORIES

## Respingenti ferro tipo -B- corsa doppia Steel bumpers type -B- double stroke

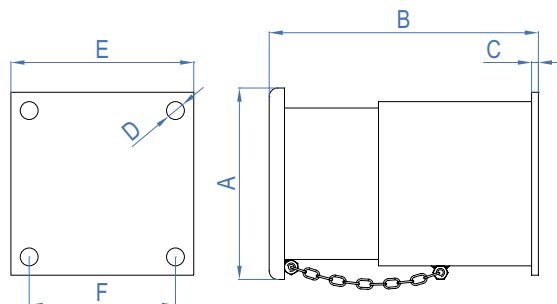

TIPO/TYPE	Forza ammortizzante Cushioning force [kg]	Corsa/Stroke [mm]	DIMENSIONI/DIMENSIONS					
			A	B	C	D	E	F
1.T	1000	80	120	263	6	11	130	100
2.T	2000	100	145	335	6	13	150	118
3.T	3000	120	175	390	7	15	170	134
5.T	5000	140	190	452	7	17	185	150
7.T	7000	150	200	502	8	19	200	162
10.T	10000	170	225	564	8	21	215	172
15.T	15000	190	250	627	10	23	260	212
20.T	20000	200	290	672	10	25	300	240
30.T	30000	220	305	775	12	25	330	263
40.T	40000	220	320	838	14	28	330	263
50.T	50000	230	350	924	16	28	350	278

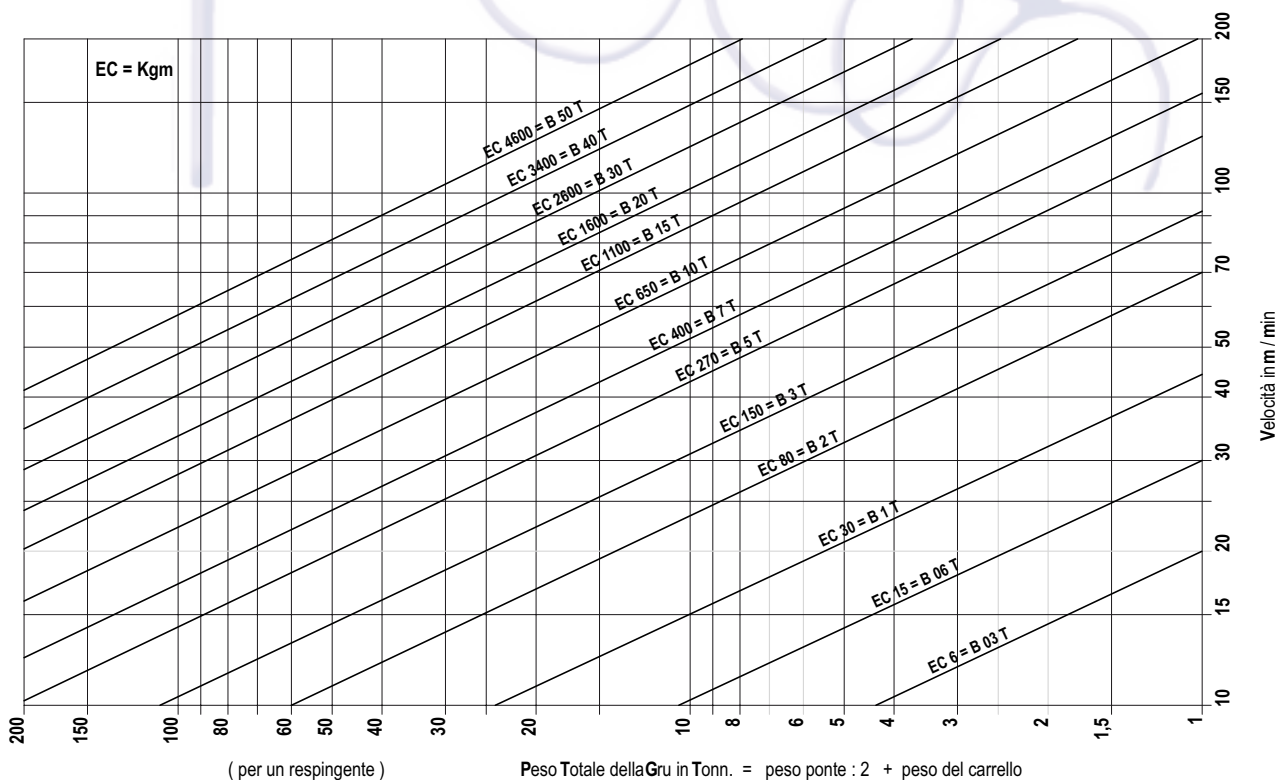

*By* CARPEL<sup>®</sup>  srl

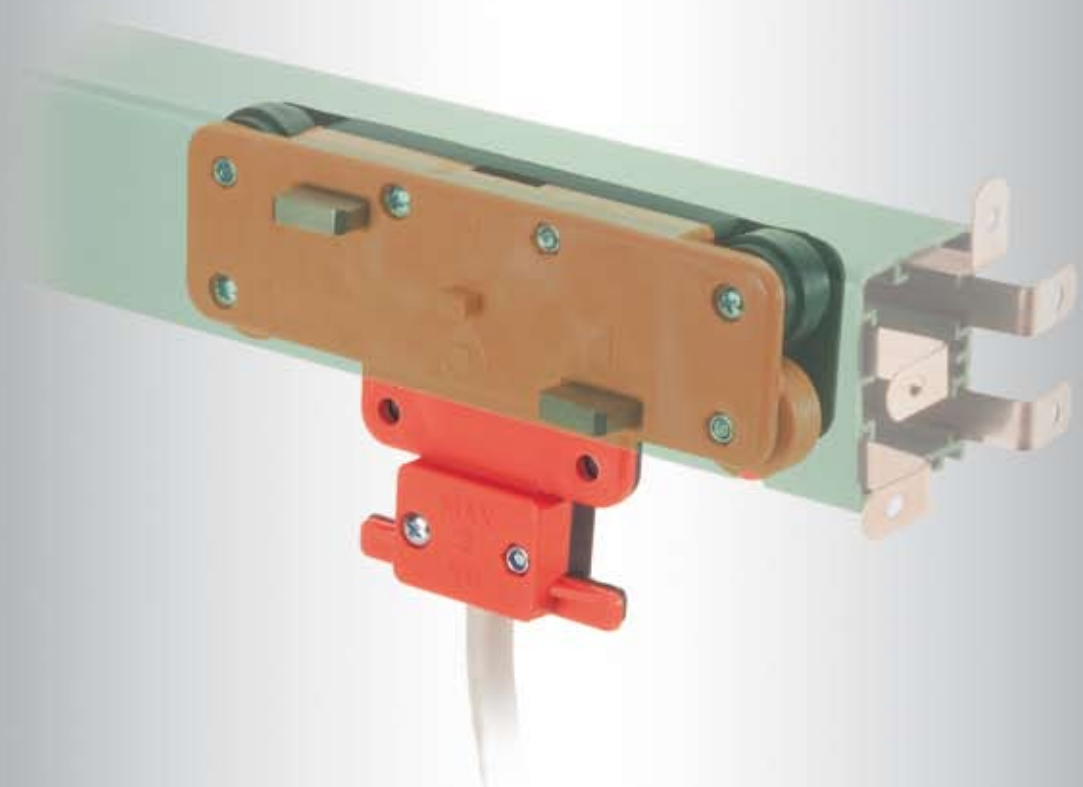

## LINEA TROLLEY ELITE

### TROLLEY ELITE LINE

La linea TROLLEY ELITE è un sistema particolarmente indicato per la distribuzione dell'energia elettrica per macchine quali gru, carriponti e macchine mobili in generale, installate all'interno o non esposte alle intemperie (pioggia, spruzzi d'acqua, .... , etc.).

La linea TROLLEY ELITE è un sistema pratico, facile da installare, efficiente, in quanto richiede una manutenzione minima, ma soprattutto sicuro. Infatti sul profilo in PVC del TROLLEY ELITE, troverete apposta la marcatura "CE" a garanzia che il prodotto è costruito conformemente ai Requisiti di Sicurezza dettati dalle Direttive:

- Direttiva CEE 73/23 e CEE 93/68 (Bassa Tensione)
- Direttiva CEE 89/336 e CEE 93/68 (EMC - compatibilità elettromagnetica) le cui prove/verifiche di sicurezza sono state eseguite in accordo alle Norme CEI EN 60439-1 e CEI EN 60439-2.

A tal proposito, nelle pagine conclusive di questo catalogo, troverete tutte le informazioni necessarie per un corretto dimensionamento, installazione e utilizzo del prodotto stesso.

*The TROLLEY ELITE line is a system particularly indicated to supply power for machine as: cranes, bridge cranes and any other mobile machine. For internal installation or not expose to rain or sprinkle or water.*

*The TROLLEY ELITE line is a practical system, easy to install, efficient, because need just a little maintenance, but it is, above all, safe.*

*In fact, the TROLLEY ELITE has been labelled with the "CE" mark to guarantee that the product meets:*

- CEE 73/23 end CEE 93/68 (Low voltage)
- CEE 89/336 end CEE 93/68 (electromagnetic compatibility)

*Test/inspections have been carried out in accordance with the effective harmonized/european standards CEI EN 60439-1 e CEI EN 60439-2. To this end, the latest pages of this catalogue show all the information required for a correct sizing, installation and use of the product allowing to safely as state in the above said Standard.*

**By CARPEL**  srl

Ci riserviamo la facoltà di apportare, senza alcun preavviso, modifiche costruttive al fine di migliorare le qualità tecniche, funzionali ed estetiche del prodotto.

*We reserve the right to make modifications in order to improve the technical, functional and aesthetical qualities of our products without any prior notice.*



AZIENDA CON SISTEMA QUALITÀ  
CERTIFICATO DA DNV  
=UNI EN ISO 9001/2000=

### Linea a conduttori continui

#### Continuous strip line

Temperatura di esercizio/Working temperature	da/ from -20 a/ to + 55°C
Alimentazione/Power supply	150 A max, 400 V, 50/60 Hz (nominali/ rated)
Grado di protezione/Degree of protection (according to CEI 70-1 I ED)	IP 20
5 poli (compreso terra)/5 Poles (ground included)	3N + T
Resistenza meccanica involucro/Mechanical resistance of the case	40 N
Resistenza a trazione sulle sospensioni/Suspension resistance and drive	fino a/ up to 680 N
Resistenza termica/Thermal resistance (glow-wire)	960°C tempo spegn./switching off time < 30 sec.
Corrente di dispersione/Leakage current	< 0,5 mA
Conduttore resistente alla corrosione/Corrosion-proofing conductor	SI
Max lunghezza interrotta della linea/Max. continuous length of th eline	120 m
Max lunghezza con accessori (P 10)/Max. length with accessories (P10)	250 m
Velocità carrello/Trolley speed	220 m/min

### Profilo a conduttore

#### Plastic casing and current strip

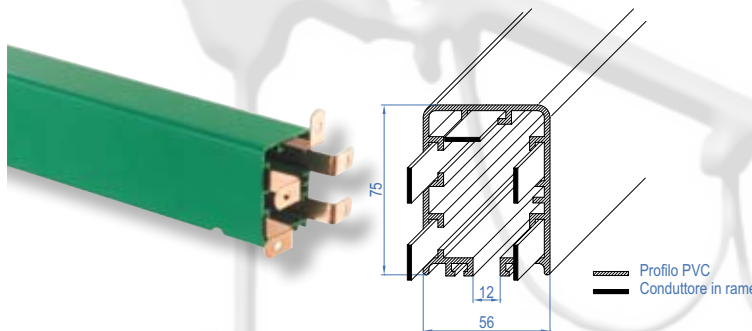

Materiale/Material	PVC
Peso involucro PVC/Weight plastic casing	1.21 kg/m
Lunghezza barre/Length's bars	da 1 a 4/ from 1 to 4 m
Colore/Colour	Grigio o verde/Grey or green

Articolo/Item	P1		
Materiale conduttore/Material of current strip	Rame/Copper		
	70A	100A	140A
Sezione conduttore/Section conductor	15.5x1	15.5x1.5	15.5x1.8
Peso conduttore/Weight conductor	0.15 Kg/m	0.20 Kg/m	0.25 Kg/m

### Sospensione

#### Suspension

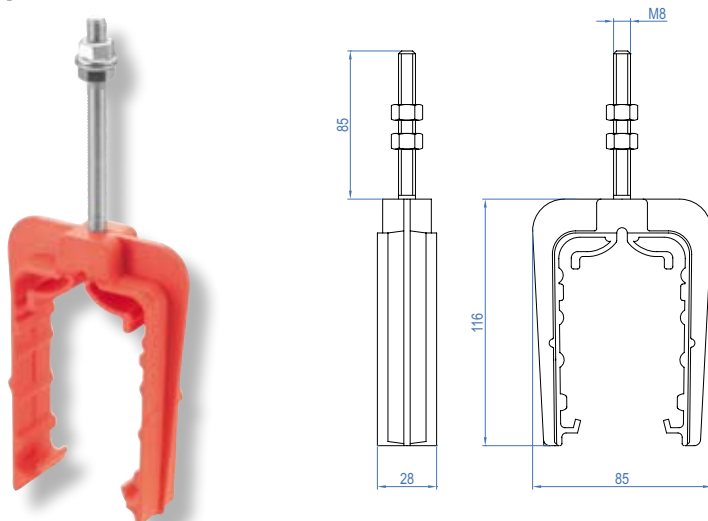

Materiale/Material	Corpo in nylon/Body nylon
	Minuteria in acciaio zincato/Small parts in galvanized steel
Peso/Weight	90 g

Articolo/Item	P2
---------------	----

### Giunto

Joint

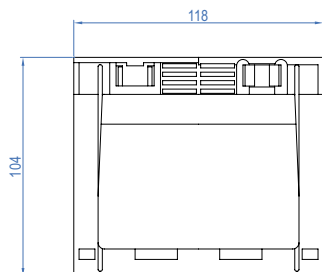
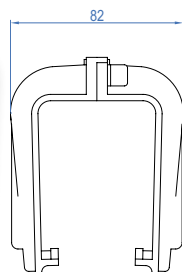

Materiale/ Material	Nylon
Peso/ Weight	115 g

**Articolo/ Item** P3

### Giunto di blocco

Line blocking joint

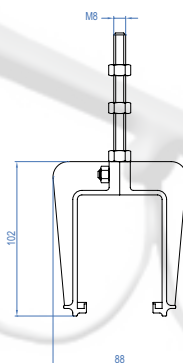
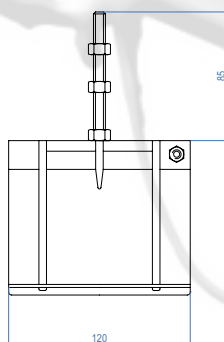

Materiale/ Material	Corpo in nylon/ Body nylon
	Minuteria in acciaio zincato/ Small parts in galvanized steel
Peso/ Weight	245 g

**Articolo/ Item** P4

### Terminale di chiusura

Closing end

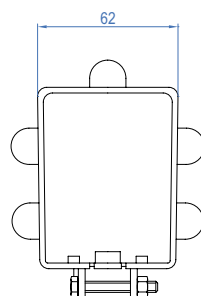
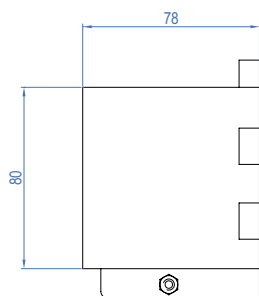

Materiale/ Material	Corpo in nylon/ Body nylon
	Minuteria in acciaio zincato/ Small parts in galvanized steel
Peso/ Weight	105 g

**Articolo/ Item** P5

### Scatola di alimentazione di testa

Head feeding

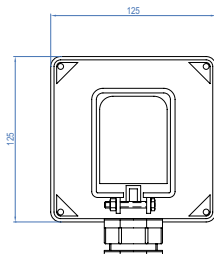
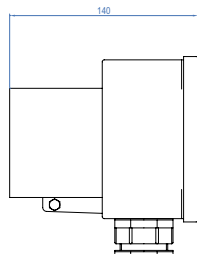

Materiale/ Material	Corpo in nylon/ Body nylon
	Minuteria in acciaio zincato/ Small parts in galvanized steel
Peso/ Weight	415 g

**Articolo/ Item** **P6**

### Scatola di alimentazione interna

Internal feeding

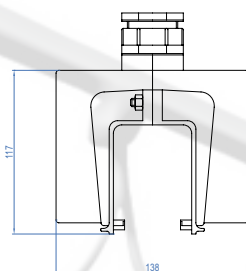
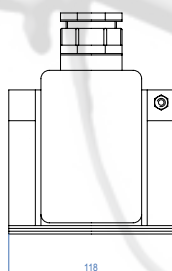

Materiale/ Material	Corpo in nylon/ Body nylon
	Minuteria in acciaio zincato/ Small parts in galvanized steel
Peso/ Weight	360 g

**Articolo/ Item** **P7**

### Carrello

Trolley

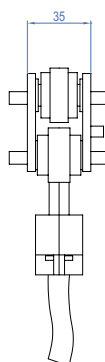
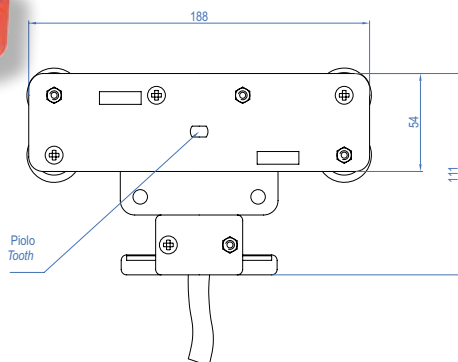

Materiale/ Material	Corpo in nylon/ Body nylon			
	Minuteria in acciaio zincato/ Small parts in galvanized steel			
	Spazzole in metalgrafite/ Sliding shoe: carbon			
Portata/ Load	32 A			
	4 poli/ poles		5 poli/ poles	
	Cavo/ Cable	Cavo/ Cable	Cavo/ Cable	Cavo/ Cable
	3m	5m	3m	5m
Peso/ Weight	1275 g	1740 g	1585 g	2050 g

**Articolo/ Item** **P8**

Per esigenze di portata superiore ai 32 A è necessario collegare in parallelo due o più carrelli.  
For higher currents and duty cycles two or more trolley have to be connected in parallel.

**Braccio di traino singolo**

Single towing arm

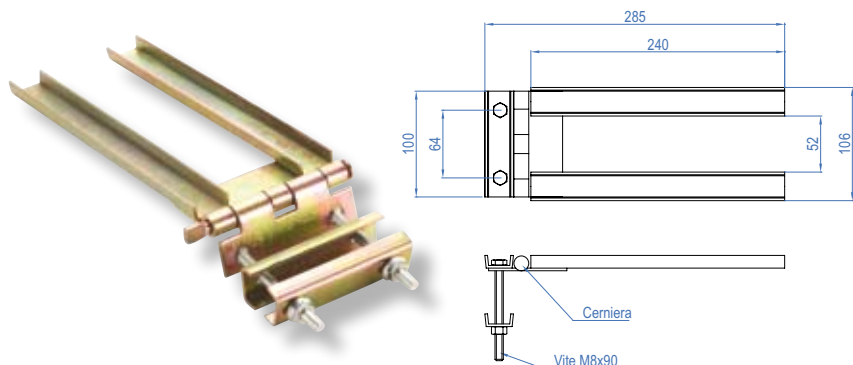

Materiale/ Material	Acciaio zincato/ Galvanized steel
Peso/ Weight	880 g

**Articolo/ Item** P9/1

**Braccio di traino doppio**

Double towing arm

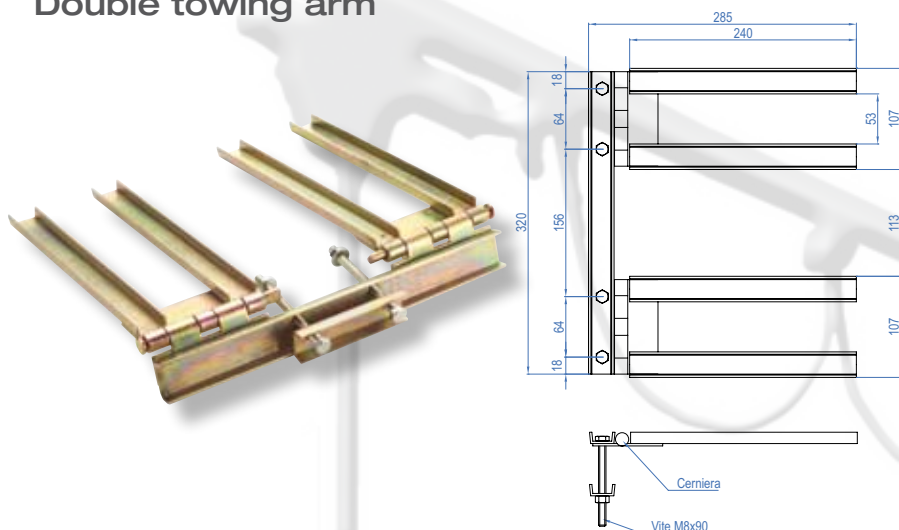

Materiale/ Material	Acciaio zincato/ Galvanized steel
Peso/ Weight	1800 g

**Articolo/ Item** P9/2

**Supporto per bracci di traino**

Support for towing arms

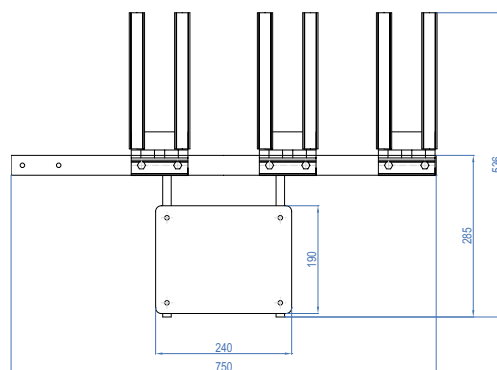

Materiale/ Material	Acciaio zincato/ Galvanized steel
Peso/ Weight	1900 g

**Articolo/ Item** P9/M



## LINEA TROLLEY ELITE

TROLLEY ELITE LINE

By CARPEL<sup>®</sup> 

### Molla di dilatazione

Expansion spring

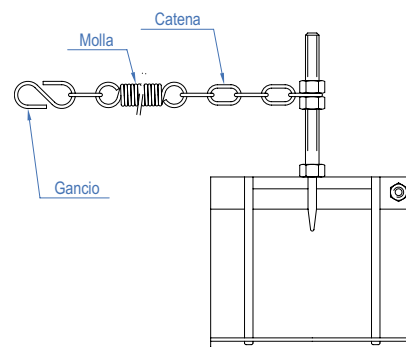

Materiale/Material	Acciaio zincato/Galvanized steel
Peso/Weight	715 g

Articolo/Item **P10**

### Guarnizione

Wascher

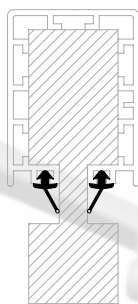

Materiale/Material	PVC semirigido/Semi-stiff PVC
Peso/Weight	65 g/m

Articolo/Item **P11**

### Blocco inserzione carrello

Trolley insertion

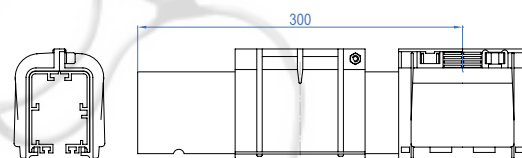
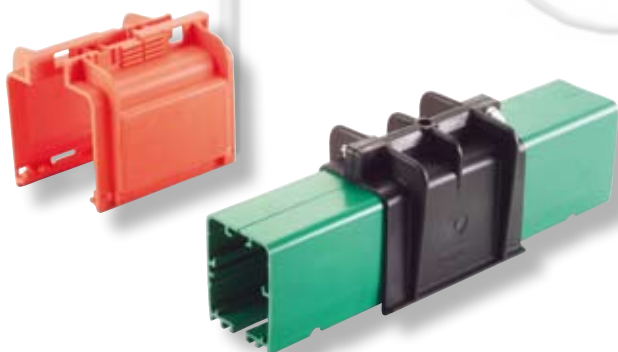

Materiale/Material	Nylon
Peso/Weight	595 g

Articolo/Item **P12**

### Mensola

Bracket

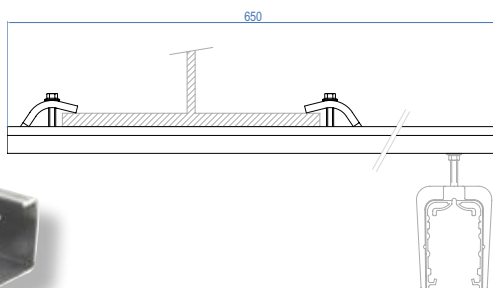

Materiale/Material	Acciaio zincato/Galvanized steel
Peso/Weight	775 g

Articolo/Item **P13**

**Accessori per il montaggio del conduttore**

Parts for conductor assembly

**Aspo svolgirame**

Reel to unwind copper



**Carrello tirarame**

Conductor guiding trolley

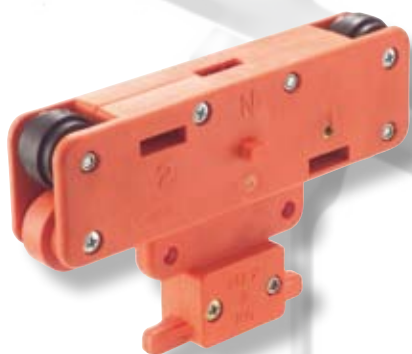

**Ricambi**

Spare parts

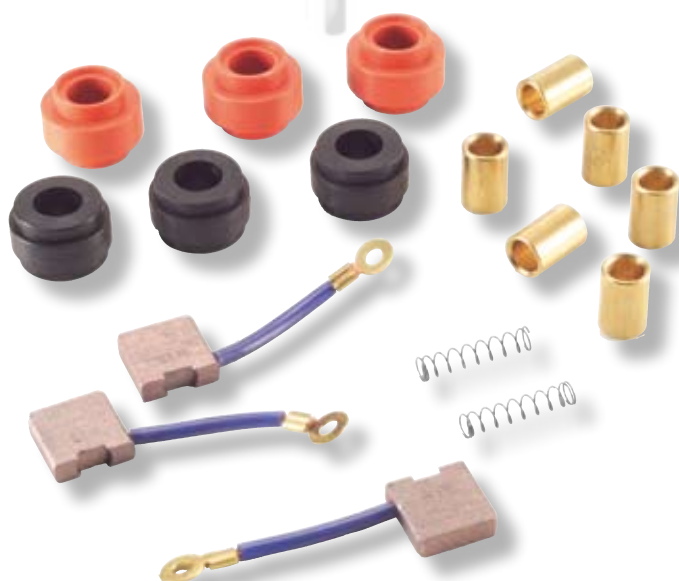

**Molla per pattino di contatto**

Spring for sliding shoe

**Ruota inferiore - superiore**

Upper - Lower wheel

**Bussola ottone ruote**

Brass bush for wheels

**Esempi di linee di alimentazione**

Example of feed line

**Linea con alimentazione di testa**

Head feed line

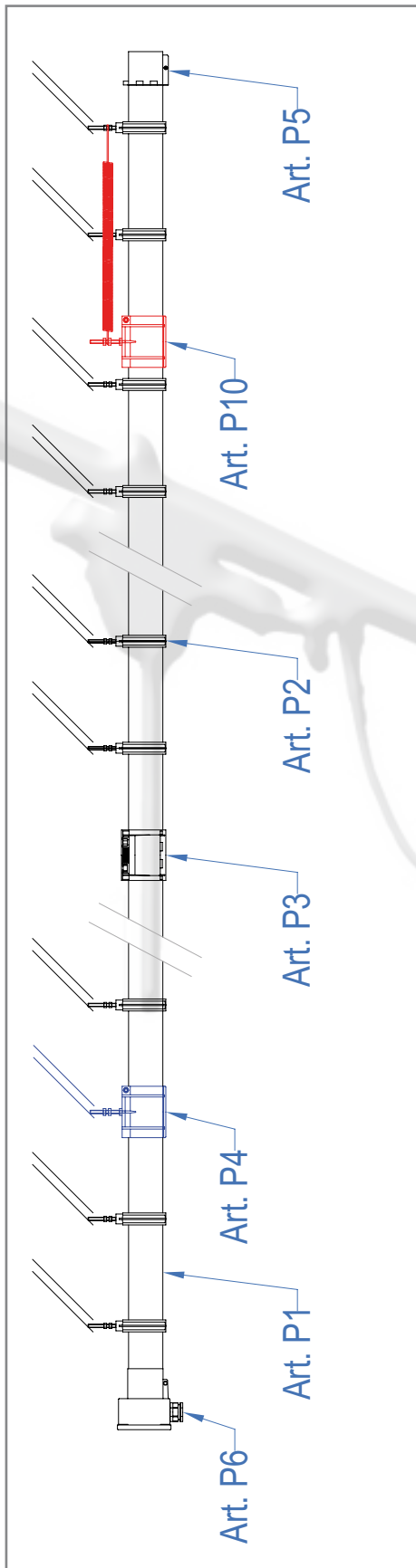

**Linea con alimentazione interna**

Inner feed line

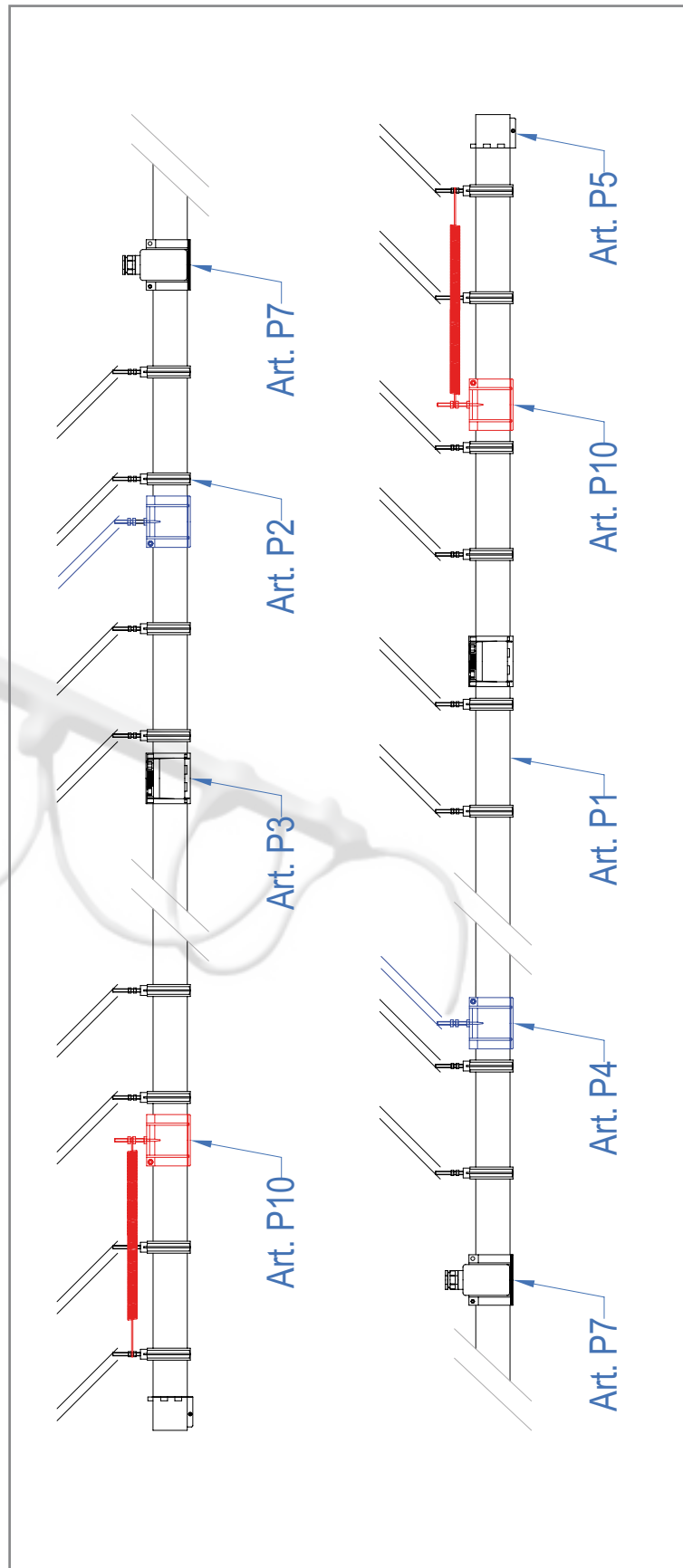

## Operazioni preliminari, materiali ed attrezzi necessari all'installazione del "TROLLEY ELITE"

- Il Trolley Elite deve essere installato su macchine dotate di almeno un dispositivo di arresto di emergenza che consenta di evitare situazioni di pericolo (requisiti dettati dal paragrafo 9.2.5.4.0 della norma EN 60204-1),
- Valutare sempre, prima di ogni operazione di installazione, manutenzione o smantellamento, la dislocazione di dispositivi di comando (pulsantiera e pannelli di controllo) e la presenza di vie di fuga.
- Si raccomanda di operare sempre e solo con giusta illuminazione, evitando zone d'ombra e luci abbaglianti.
- E' fatto obbligo al personale che installa, esegue manutenzione o dismette l'impianto, l'uso precauzionale di protezioni individuali, quali ad esempio imbracature e guanti.
- Il carrello tiramide è indispensabile qualsiasi sia la lunghezza della linea.
- L'aspo svolgirame risulta di utilità solo in caso di montaggio di linee con lunghezza superiore a 100 m. ( dato il notevole peso del conduttore, risulterebbe poco agevole e insicura un'installazione in mancanza dell'aspo svolgirame).
- Le barre di profilo (art.P1) sono dotate di diciture e indicazioni solo su un lato. L'installatore deve avere l'accortezza di assemblare le barre mantenendo le diciture sempre sullo stesso lato; così facendo viene posizionato automaticamente il contro-piolo che impedisce l'inserimento del carrello in posizioni errate.
- Dare tensione all'apparato solo dopo aver controllato il suo buon funzionamento.
- Le operazioni di installazione e assemblaggio devono essere eseguite solo da personale qualificato.

### IL CARICO MECCANICO AMMESSO E' DI 5 kg OGNI 2 m DI PROFILO

## Preliminary instruction, material and tools necessary to install the "TROLLEY ELITE"

- *The TROLLEY ELITE may be installed on machine equipped with a safety device that allow to avoid a danger ( requisite of par. 9.2.5.4.0 of EN 6024-1).*
- *To check, before ever operation of installation, maintenance or dismantling, the position of control device ( push-button and control panel ) and the presence of escape way.*
- *It's recommended to work ever and only with the right lighting, to shun the shade and dazzling light.*
- *It's obligatory, for the people that install, to make maintenance or dismantling, to use the personal protection such as: slinging, elmet and glove.*
- *The guide-conductor trolley is essential for every line lenght.*
- *The unrollkopper swift is necessary only when there are line with lenght over 100 m ( because the roll of copper becomes hard to hold up ).*
- *The bars of PVC are furnished of wording and indications only one side. The operators have to assemble the bars with the all wording on the same side; in order to facilitate the mounting of the line and to prevent the wrong insertion of the trolley.*
- *To give voltage to the contrivance only after have controlled the right working.*
- *The operations of installations and assemblage must be executed only from qualified staff.*

### THE LOAD ALLOWD IS 5 Kg EVERY 2 METERS OF BAR

## Montaggio della linea avente alimentazione di testata

Nel caso si debba montare la linea con alimentazione di testa fare riferimento alla Fig.1.

- 1- Infilare per ogni barra di profilo da utilizzare (art.P1 ) n° 2 sospensioni (art.P2).
- 2- Procedere con il fissaggio delle barre alle mensole; il collegamento statico delle varie barre è realizzato mediante il giunto ( art.P3 ).
- 3- Accertarsi che i becchi inferiori dei giunti siano inseriti nelle apposite cavità del profilo.
- 4- Inserire il giunto di blocco linea ( art.P4).
- 5- Allineare perfettamente la linea d'alimentazione regolando le viti delle sospensioni.
- 6- Fissare la scatola di alimentazione di testa (art.P6) all'estremità della linea mediante le apposite viti fornite insieme all'apparecchio.
- 7- A questo punto avviene l'inserimento della banda conduttrice nella barra ( il conduttore viene fornito in rotoli)

NOTA: la banda conduttrice è già stata precedentemente forata per facilitare le operazioni di fissaggio nella scatola di alimentazione e il fissaggio del carrello tirarame.

8- Il cablaggio dell'alimentazione di testa (art.P6) deve essere effettuato collegando:

- la terra in corrispondenza delle bande colorate lateralmente sulle barre.
- il neutro ( N ) alla parte centrale superiore della scatola di alimentazione (art.P6/P7)
- le altre fasi si faccia riferimento alla Fig. 3

9- Terminato l'inserimento dei conduttori infilare il carrello di presa corrente nel profilo.

NOTA: onde evitare l'inserimento del carrello nella direzione errata, esso viene fornito con un contropiolo in rilievo.

10- Fissare il terminale di chiusura ( art.P5 )

NOTA: L'art.P12 (blocco inserzione carrello) è consigliato nei casi di linee di alimentazione che forniscono energia a 2 o più macchine. Una linea così composta , faciliterà, sia in fase di montaggio che di manutenzione, lo scollegamento del carrello.

### MONTAGGIO DELLA LINEA AVENTE ALIMENTAZIONE INTERNA

Nel caso si debba montare la linea con alimentazione interna, il procedimento è simile al precedente avendo però l'accortezza di partire dal centro della linea con il componente art. P7.

## Mounting head feeding

*Fir the line mounting with head feeding, see the figure 1*

- 1- Insert N° 2 suspension art.P2 in each bar art.P1.
  - 2- Fix the bars on the bracked.
  - 3- Join the bars with the proper joint art.P3 and check that the teeth of the joint are inserted in the cavity of the profile.
  - 4- Insert the blocking joint art.P4.
  - 5- Line up perfectly the line adjusting the screws of the suspensions.
  - 6- Fix the head feeding box art.P6 to the extremity of the line with the proper screws which are furnished with the line.
  - 7- To this point there is the introduction of the conductor in the bar, which is delivered in rolls. NOTE: the current strip is bored in order to facilitate the fixing in the feeding box and for the guide-conductor trolley.
  - 8- For the earth feeding connection check the coloured lines position on the bars. The neutral is always positioned on the central part of head feeding box, for all the others phases see figure 3.
  - 9- When the introduction of the conductor is finished. Insert the trolley art.P8.
- N.B. the trolley is provided with a relief tooth, exclusive BY CARPEL, for to prevent wrong mounting.*
- 10- Fix the closing end art. P5.

*N.B. The art.P12, trolley insertion, is recommended for line that supply power to 2 or more machine, so it's more easy to install and to dismantle the trolley.*

### MOUNTING INTERNAL FEEDING

*For the line mounting with internai feeding art.P7 it's necessary to begin from the center of the line; the prodeeding is the same as the previous one.*

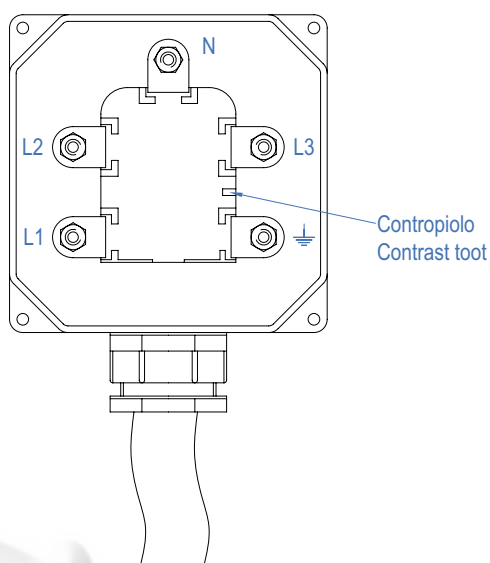

**L'IDENTIFICAZIONE DELLE FASI DI CONNESSIONE DEVE ESSERE EFFETTUATA OBBLIGATORIAMENTE DALL'INSTALLATORE DELLA LINEA, UTILIZZANDO LE APPOSITE ETICHETTE FORNITE.**

*Identification of logon phases must be obligatory done from the person who mount the line using the appropriate supplied labels.*

Fig. 3: ESEMPIO DI CONNESSIONE DEI CONDUTTORI (Art. P6)  
Fig. 3: MODALITY OF CONNECTION OF CONDUCTORS(Art.P6)

La linea TROLLEY ELITE è stata progettata, costruita ed equipaggiata in modo tale da limitare le cause di intervento degli operatori. Il TROLLEY ELITE non richiede particolari e difficili operazioni di manutenzione; attenendosi scrupolosamente alle indicazioni di seguito elencate, si otterrà la massima funzionalità e la massima durata del prodotto.

- Dopo i primi tre mesi dalla messa in funzione della linea d'alimentazione verificare il perfetto allineamento delle sbarre, verificare inoltre che il TROLLEY ELITE sia parallelo alle rotaie dell'impianto ( gru, carroponete, etc .. )
- Ogni sei mesi controllare che i pattini di contatto abbiano una sporgenza dal lato esterno del carrello di almeno 5 mm, nel caso contrario si rende necessaria la sostituzione dei pattini e/o delle molle.
- Ad ogni operazione di manutenzione verificare lo scorrimento del carrello nelle sedi, se queste ultime risultassero occluse da polvere o altro, rimuovere il materiale ostruente.
- Accertarsi che la cerniera del traino sia oliata
- Durante ogni operazione è vietato l'uso di mezzi impropri (colpi di martello, etc .. )

NOTA: per sfilare il carrello si può rimuovere il terminale di chiusura, oppure se è stato montato l'apposito "blocco inserimento carrello", è sufficiente smontare lo stesso (art. P12).

**TUTTE LE OPERAZIONI DI MANUTENZIONI DEVONO VENIRE EFFETTUATE AD IMPIANTI FERMI E NON SOTTO TENSIONE.**

*The TROLLEY ELITE line is projected, built and fitted, to limit the intervention of the operators. The TROLLEY ELITE doesn't need particular and difficult operation of maintenance. If you follow the indication you can obtain the best functionality and the best duration of the line.*

- After three month, verify the perfect alignment of the line; verify that the TROLLEY ELITE is parallel to the rail of the machine (crane, etc.).
- Every six month check that the sliding shoes sticks out about 5 mm, or else it's necessary to replace the sliding shoes and the spring.
- During every operation of maintenance, verify the sliding of the trolley in the bars; or else removethe dust and every thing that can block up the sliding of the trolley.
- Verify that the hinge of the towing arm is oiled.
- During every operation is forbbiden to used improper means ( as hammer-stroke, etc.).

*N.B. To dismantle the trolley is possible remove the closing end or, if the "trolley insertion" art. P.12 is mounted, is possible remove it.*

**EVERY OPERATION OF MAINTENANCE MUST BE EFFECTED WITH EVERY EQUIPMENT STOPPED AND WITHOUT TENSION .**

*By* CARPEL<sup>®</sup> srl 

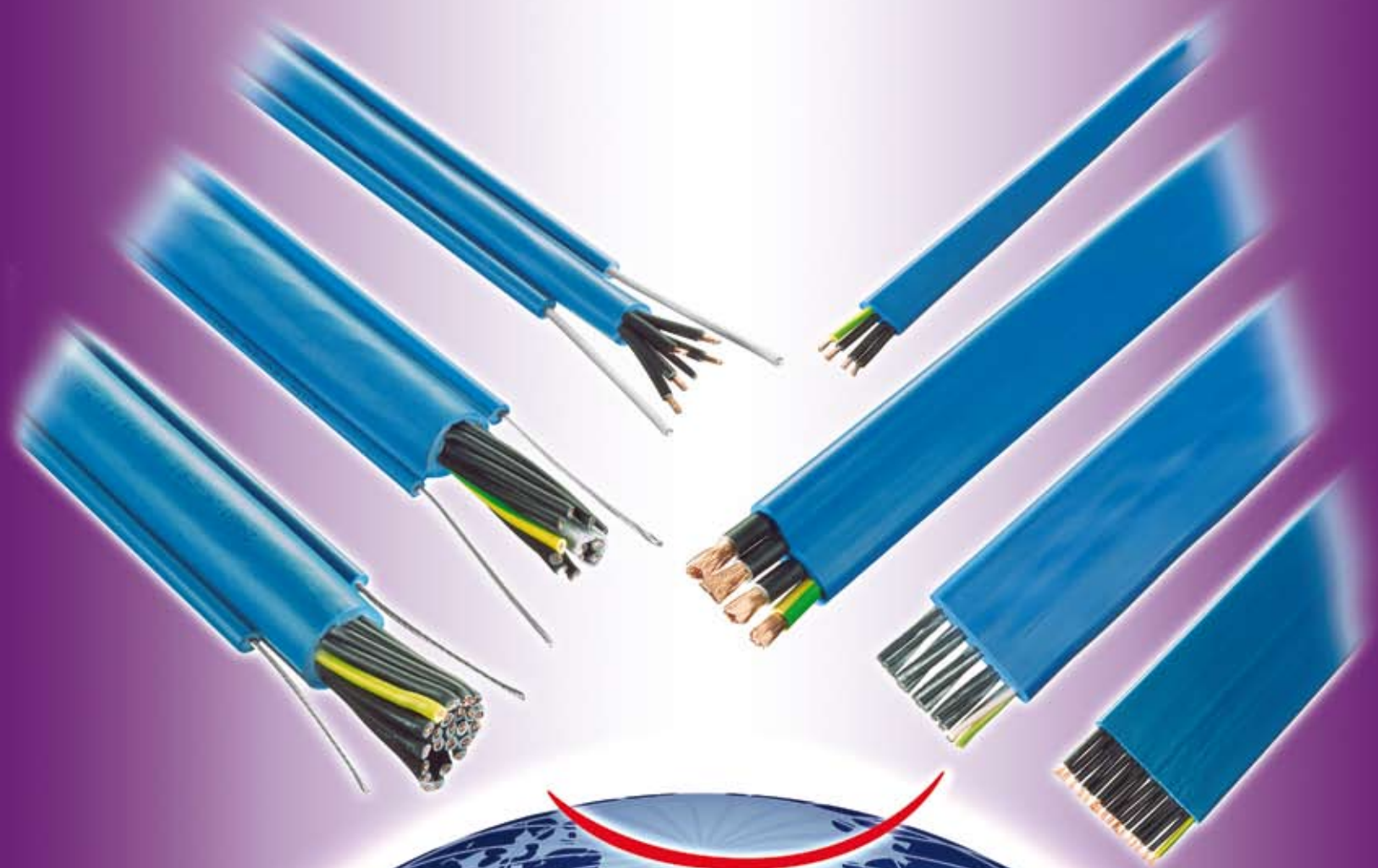

## CAVI AUTOPORTANTI UTENZE MOBILI SELF-SUPPORTING CABLES FOR MOVING EQUIPMENT

**By CARPEL<sup>®</sup>**   
srl

Ci riserviamo la facoltà di apportare, senza alcun preavviso, modifiche costruttive al fine di migliorare le qualità tecniche, funzionali ed estetiche del prodotto.

*We reserve the right to make modifications in order to improve the technical, functional and aesthetical qualities of our products without any prior notice.*



AZIENDA CON SISTEMA QUALITÀ  
CERTIFICATO DA DNV  
=UNI EN ISO 9001/2000=



# CAVI PIATTI PER UTENZE MOBILI

## FLAT CABLES FOR MOVING EQUIPMENT



### Denominazione/Description: H07VVH6-F

N° conduttori conductors x mm <sup>2</sup>	Dimensioni Size mm x mm	Peso Weight g/m	mm <sup>2</sup>	Portata Capacity max.amp.
4x1,5	5,4x15,6	160	6	20
8x1,5	5,4x29,1	310	12	20
12x1,5	5,4x42,6	470	18	20
16x1,5	5,4x56,1	630	24	20
18x1,5	11,2x46,1	700	27	20
20x1,5	11,4x47,1	780	30	20
24x1,5	11,8x46,5	950	36	20
4x2,5	6,0x19,0	220	10	27
8x2,5	8,2x24,3	440	20	27
12x2,5	6,0x52,6	650	30	27
16x2,5	12,9x40,2	890	40	27
18x2,5	11,6x51,6	1010	45	27
4x4	6,9x21,0	330	16	36
4x6	7,7x24,2	450	24	48
4x10	10,1x30,2	720	40	63
4x16	11,0x35,4	1100	64	85
4x25	12,3x40,8	1550	100	112
4x35	15,4x49,9	2100	140	138
4x50	20,2x64,1	3150	200	168

Diametro esterno nominale - Tolleranza +/- 0,5 mm  
Nominal outer diameter - Tolerance +/- 0,5 mm

### Formazione e costruzione cavi/Formation

N° conduttori N° conductors	6	9	12	16	20	24
N° conduttori per gruppo N° conductors for group	2x3	3x3	3x4	4x4	5x4	6x4

Sezione mm <sup>2</sup> Section mm <sup>2</sup>	0,75	1,5	2,5	4	6	10
Resistenza elettrica Conductors resistance	26,00	13,30	7,98	4,95	3,30	1,91

Sezione mm <sup>2</sup> Section mm <sup>2</sup>	16	25	35	50
Resistenza elettrica Conductors resistance	1,21	0,78	0,55	0,38

### Costruzione/Construction

H - Cavo armonizzato/Harmonized cable  
 O5 - Tensione nominale/Nominal tension 2 U<sub>0</sub>/U: 300/500 V oppure/or  
 O7 - Tensione nominale/Nominal tension 3 U<sub>0</sub>/U: 450/750 V  
 V - Isolamento PVC tipo T12/Insulation with T12 PVC  
 V - Guaina PVC tipo TM 2/Outer sheath with TM2 PVC  
 H6 - Cavo piatto con più di 4 conduttori/Flatform cable with more than 4 conduct  
 F - Conduttore di tipo flessibile/Flexible conductors

F - Conduttore di tipo flessibile/Flexible conductors  
 R - Isolamento PVC tipo T1/Insulation with T1 PVC  
 D - Cavo piatto/Flatform cable  
 R - Guaina PVC tipo TM 2/Outer sheath with TM2 PVC

### Identificazione/Identification

Identificazione anime secondo tabella CEI-UNEL 00722: con numerazione progressiva, con o senza conduttore di protezione giallo verde. Guaina esterna di preferenza in colore blu. Su specifica richiesta del cliente e per quantitativi minimi di 3-4000 m, possibilità di fornitura in colore nero.  
 Cores identification according to CEI-UNEL 00722 tables; usually with progressive numbering, with or without green-yellow conductor: Blue outer sheath.  
 On request and for minimum quantitative or 3-4000 m, possibility of supplying with black outer sheath.

### Norme di riferimento/Standards

CEI 20-27 sigle di designazione  
 Tabella UNEL 35010 sigle di designazione  
 CEI 20-29/IEC 228 conduttori cavi isolati/conductors for insulated cables  
 CEI 20-20/IEC 227 cavi isolati per PVC/PVC insulated cable  
 CEI 20-35/IEC 332.1 non propagazione della fiamma/Flame retardant  
 CEI 20-25 cavi flessibili piatti sotto guaina di PVC, per ascensori  
 CENELEC HD 359 S2

### Impiego/Application

Cavi adatti per installazione su macchine mobili velocità di spostamento non superiore a 1.6 m/s, con temperatura ambiente non inferiore a 15°C e superiore a +80°C.  
 Cable used in moving equipment with shifting rate of 1.6 m/s. To be used at temperature ranging from -15°C and +80°C.

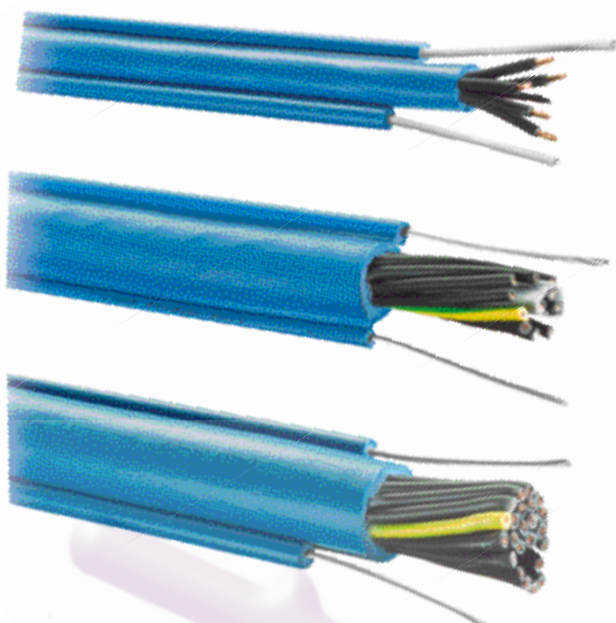

**Formazione e costruzione cavi/Formation**

N° conduttori N° conductors x mm <sup>2</sup>	Dimensioni Size mm x mm	Peso Weight g/m	mm <sup>2</sup>
5X1	9,8x20,0	230	5
7x1	9,8x20,0	250	7
8x1,5	13,9x26,0	420	12
10x1	13,8x26,5	350	10
12x1,5	17,3x32,0	560	18
16x1,5	19,1x34,0	640	24
18x1,5	20,0x35,0	730	27
20x1,5	21,1x35,6	790	30
24x1,5	23,0x37,6	880	36
<b>Diametro esterno nominale - Tolleranza +/- 0,5 mm</b> <b>Nominal outer diameter - Tolerance +/- 0,5 mm</b>			

**Costruzione/Construction**

FF - Conduttore extraflessibile rame rosso o stagnato/*Extra-flexible conductors in plain or tinned annealed copper*  
 R - Isolamento PVC tipo T12/*Insulation with T12 PVC*  
 07 - Cordatura a corone concentriche separate tra loro da nastro tessile/*Lay-up in concentric layers separated by a textile tape*  
 Y - Funi in acciaio zincato/*Galvanized steel ropes*  
 R - Guaina PVC tipo TM 2/*Outer sheath in TM2 PVC*

**Identificazione/Identification**

Identificazione anime secondo tabella CEI-UNEL 00722: con numerazione progressiva, con o senza conduttore di protezione giallo verde. Guaina esterna di preferenza in colore blu. Su specifica richiesta del cliente e per quantitativi minimi di 3-4000 m, possibilità di fornitura in colore nero.  
*Cores identification according to CEI-UNEL 00722 tables; usually with progressive numbering, with or without green-yellow conductor. Blue outer sheath.*  
*On request and for minimum quantitative or 3-4000 m, possibility of supplying with black outer sheath.*

**Norme di riferimento/Standards**

Tabella UNEL 35010 sigle di designazione  
 CCEI 20-29/IEC 228 conduttori cavi isolati/*conductors for insulated cables*  
 CEI 20-20/IEC 227 cavi isolati per PVC/*PVC insulated cable*  
 CEI 20-35/IEC 332.1 non propagazione della fiamma/*Flame retardant*

**Impiego/Application**

In questo cavo di comando gli sforzi di trazione vengono sostenuti da 2 funi laterali inserite nella guaina esterna. Le funicelle hanno una resistenza alla trazione di 2100 N. Il cavo trova la sua applicazione in pulsantiere pensili, macchine per cantieri e sistemi di movimentazione e sollevamenti.  
 Per migliorare la flessibilità il fascio interno dei conduttori è rivestito da un nastro tessile che migliora le possibilità di movimento reciproco fra i conduttori e la guaina.  
*The tensile stress in this control cable is supported by 2 side ropes inserted in the outer sheath. The steel ropes have a tensile strength of 2100 N: The cable is used in pendant push-button panels, yard machines, handling and lifting systems.*  
*In order to improve flexibility, the inner conductor bundle is wrapped in a textile tape which improves the capability of reciprocal motion between conductors and outer sheath.*