

MISIA



Paranchi a tiro centrale 4/2
True vertical lift 4/2

Paranchi standard SERIE XM
XM SERIES standard hoists

**PARANCHI A DOPPIA USCITA
DAL TAMBURO D2 (4/2) TIRO CENTRALE**
HOISTS WITH DOUBLE OUTPUT
FROM THE DRUM D2 (4/2) TRUE VERTICAL LIFT



D2 - 4 TIRI DI FUNE (4/2) TIRO CENTRALE
D2 - 4 ROPE FALLS (4/2) TRUE VERTICAL LIFT

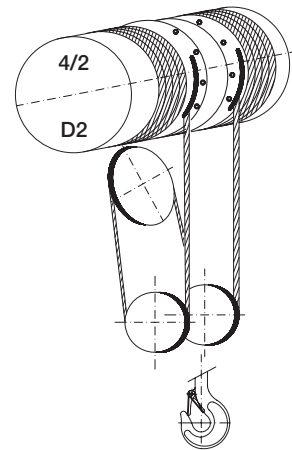

CARATTERISTICHE TECNICHE - TECHNICAL DATA

Portata max Max capacity	Gruppo Group	Paranco Hoist	Tiri fune Rope falls	Corse gancio Hook travel			Velocità sollevamento (m/min) Lifting speed (m/min)					
							1 velocità 1 speed		2 velocità 2 speed			
									Motori cilindrici Cylindrical motors		Motori conici Conical motors	
kg	FEM	XM		m	m	m	N	V	NA	VA	NA	VA
1600	2 m	308 D2	4/2	6	10	13	8	12	8/2,6	12/4	8/2,6	12/4
2500	2 m	312 D2	4/2	7,5	12	16	8	12	8/2,6	12/4	8/2,6	12/2
3200	2 m	316 D2	4/2	7,5	12	16	8	12	8/2,6	12/4	8/1,3	12/2
5000	2 m	525 D2	4/2	6	10	14	8	12	8/2,6	12/4	8/1,3	12/2
8000	1 Am	740 D2	4/2	7	11,5	16	8	12	8/2,6	/	8/1,3	/
10000	1 Am	750 D2	4/2	7	11,5	16	5	8	/	8/2,6	5/1,2	/
10000	2 m	963 D2	4/2	8	16	25	7,5	/	7,5/2,5	/	6/1,5	/
12500	1 Am	963 D2	4/2	8	16	25	7,5	/	7,5/2,5	/	5/1,2	/
16000	1 Am	980 D2	4/2	8	16	25	7,5	/	/	/	5/1,2	/

Le velocità sono riferite a una frequenza di 50 Hz / The lifting speed refers to a frequency of 50 Hz

REAZIONE AI PIEDINI - FOOT REACTION

$$\frac{P + P_p}{2} = \text{Kg}$$

P (Portata / Capacity)
P_p (Peso paranco / Hoist weight)

Paranchi standard SERIE XM

XM SERIES standard hoists

PARANCO A PIEDINI

FOOT MOUNTED HOIST

PARANCI A DOPPIA USCITA

DAL TAMBURO D2 (4/2) TIRO CENTRALE

HOISTS WITH DOUBLE OUTPUT

FROM THE DRUM D2 (4/2) TRUE VERTICAL LIFT

Tipo 5 APPOGGIATO - SUPPORTED

Tipo 5C1 SOSPESO - SUSPENDED

XM 308 / 312 / 316 / 525

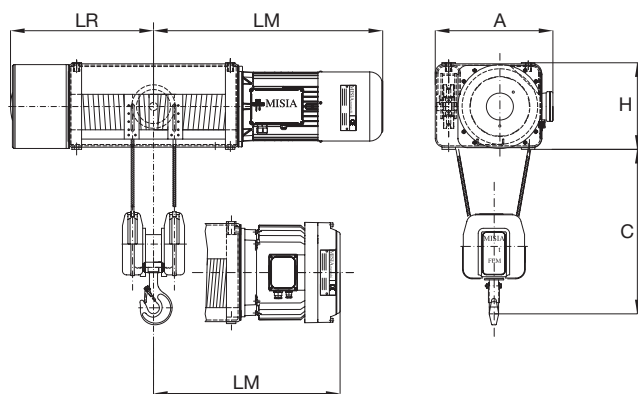

XM 740 / 750 / 963 / 980

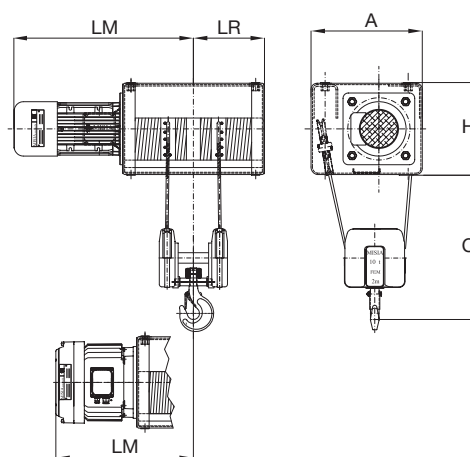

D2 (4/2) A 4 TIRI DI FUNE - D2 (4/2) 4 ROPE FALLS

Paranco Hoist	Portata Capacity	Corsa gancio Hook travel	Dimensioni Dimensions				Motori cilindrici Cylindrical motors				Motori conici Conical motors				Peso Weight		
			C mm	H mm	A mm	LR mm	Speed m/min	LM mm	Speed m/min	LM mm	Speed m/min	LM mm	Speed m/min	LM mm		Kg	
308	1,6	6	500	325	460	460	N	790	V	790	N	645	V	702	300		
		550				880						880		810		320	
		645				975						975		910			340
312	2,5	7,5	540	325	460	535	N	815	V	895	N	705	V	705	370		
		640				920						1000		810		400	
		740				1020						1100		910			430
316	3,2	7,5	540	325	460	535	N	835	V	895	N	705	/	/	460		
		640				940						1000				810	490
		740				1040						1100				910	
525	5	6	580	380	510	565	N	905	V	965	N	750	V	805	550		
		670				1010						1070		860		590	
		770				1110						1170		960			630
740	8	7	720	530	720	405	N	1030	/	/	N	870	/	/	770		
		510				1135						975				810	860
		620				1245						1085				860	
750	10	7	720	530	720	405	N	1030	/	/	N	870	V	890	770		
		510				1135						975		995		810	
		620				1245						1085		1105			860
963	10	8	760	625	810	480	N	1100	/	/	N	940	/	/	1150		
		690				1210						1150				1300	
		940				1560						1400				1480	
963	12,5	8	760	625	810	480	N	1100	/	/	N	940	/	/	1150		
		690				1210						1150				1300	
		940				1560						1400				1480	
980	16	8	780	625	810	480	N	1180	/	/	N	960	/	/	1170		
		690				1390						1170				1320	
		940				1640						1420				1500	

N - V - N A - V A = velocità di sollevamento (vedi pagina 56) / lifting speeds (see page 56)



Paranchi standard SERIE XM XM SERIES standard hoists

PARANCO CON CARRELLO MONOTRAVE HOIST WITH MONORAIL TROLLEY

PARANCHI A DOPPIA USCITA DAL TAMBURO D2 (4/2) TIRO CENTRALE HOISTS WITH DOUBLE OUTPUT FROM THE DRUM D2 (4/2) TRUE VERTICAL LIFT

Tipo 3 A INGOMBRO NORMALE - NORMAL HEADROOM

XM 308 / 312 / 316 / 525

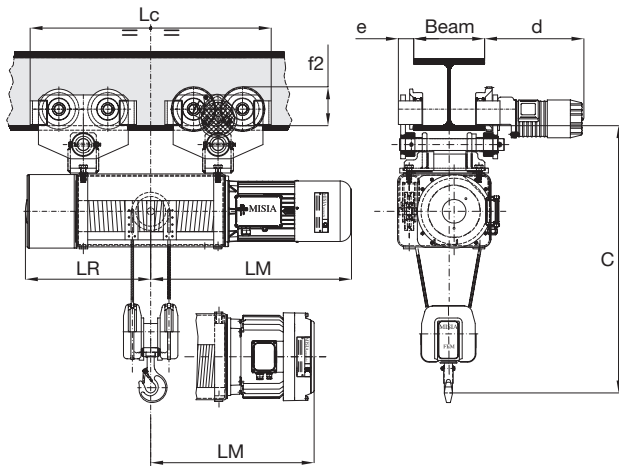

XM 740 / 750 / 963 / 980

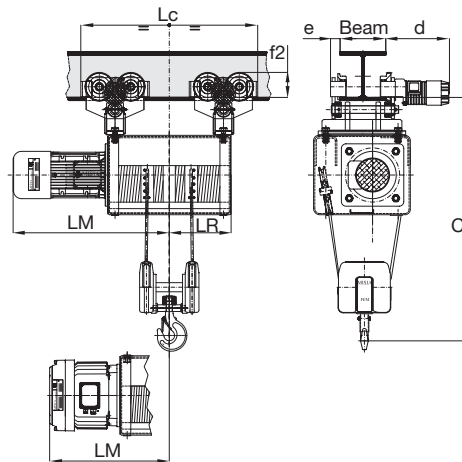

TIPO 3 CON CARRELLO MONOROTAIA D2 (4/2) A 4 TIRI DI FUNE - TYPE 3 MONORAIL TROLLEY D2 (4/2) 4 ROPE FALLS

Paranco Hoist	Portata Capacity	Corsa gancio Hook travel	Dimensioni Dimensions						Motori cilindrici Cylindrical motors				Motori conici Conical motors				Peso Weight
			C mm	d mm	e mm	Lc mm	LR mm	f2 mm	Speed m/min	LM mm	Speed m/min	LM mm	Speed m/min	LM mm	Speed m/min	LM mm	
308	1,6	6	1000	410	60	920	460	145	N	790	V	790	N	645	V	705	430
		1100				550	880		810	810	450						
		1285				645	975		VA	975	NA	830	VA	910	470		
312	2,5	7,5	1040	410	60	970	535	145	N	815	V	895	N	705	V	705	500
		1175				640	920		1000	810	810	530					
		1375				740	1020		VA	1100	NA	910	VA	910	560		
316	3,2	7,5	1040	410	60	970	535	145	N	835	V	895	N	705			590
		1175				640	940		1000	810	/	/	620				
		1375				740	1040		VA	1100	NA	910			660		
525	5	6	1140	410	60	990	565	145	N	905	V	965	N	750	V	805	610
		1175				670	1010		1070	860	910	660					
		1395				770	1110		VA	1170	NA	960	VA	1010	700		
740	8	7	1510	430	70	1165	405	165	N	1030			N	870			1000
		1380				510	1135		/	/	975	/	/	1040			
		1595				620	1245				1085			1090			
750	10	7	1510	430	70	1165	405	165	N	1030			N	870	V	890	1000
		1380				510	1135		/	/	975			995	1040		
		1595				620	1245				1085	VA	1105	1090			
963	10	8	1650	430	70	1290	480	165	N	1100			N	940			1400
		1705				690	1135		/	/	1150	/	/	1550			
		2205				940	1245				1400			1730			
963	12,5	8	1650	430	70	1290	480	165	N	1100			N	940			1420
		1705				690	1210		/	/	1150	/	/	1570			
		2205				940	1560				1400			1750			
980	16	8	1650	300	70	1290	480	165	N	1180			N	960			1440
		1705				690	1390		/	/	1170	/	/	1590			
		2205				940	1640				1420			1770			

Velocità carrello / Trolley speed: 18 - 18/6 m/min

N - V - N A - V A = velocità di sollevamento (vedi pagina 56) / lifting speeds (see page 56)

REAZIONI ALLA SINGOLA RUOTA - SINGLE WHEEL REACTION

$$\frac{P + P_p}{2 \cdot 4} = K_g$$

P (Portata / Capacity)
P_p (Peso paranco / Hoist weight)

Paranchi standard SERIE XM XM SERIES standard hoists

PARANCO CON CARRELLO MONOTRAVE HOIST WITH MONORAIL TROLLEY

PARANCI A DOPPIA USCITA DAL TAMBURO D2 (4/2) TIRO CENTRALE HOISTS WITH DOUBLE OUTPUT FROM THE DRUM D2 (4/2) TRUE VERTICAL LIFT

Tipo 83 CARRELLO MONOTRAVE A INGOMBRO RIDOTTO MONORAIL TROLLEY LOW HEADROOM



XM 308 / 312 / 316 / 525

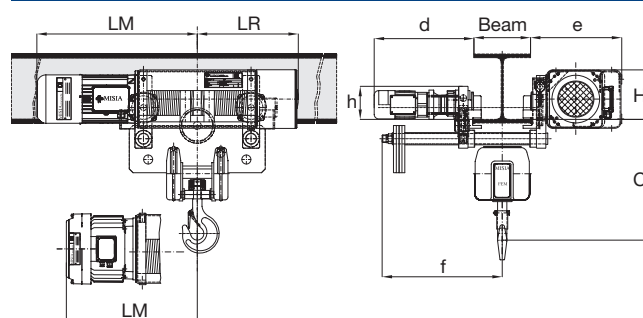

D2 (4/2) A 4 TIRI DI FUNE - D2 (4/2) 4 ROPE FALLS

Paranco Hoist	Portata Capacity	Corsa gancio Hook travel	Dimensioni Dimensions							Motori cilindrici Cylindrical motors				Motori conici Conical motors				Peso Weight
			C mm	H mm	h mm	d mm	e mm	f mm	LR mm	Speed m/min	LM mm	Speed m/min	LM mm	Speed m/min	LM mm	Speed m/min	LM mm	
308	1,6	6	660	240	140	430	470	410	460	N	790	V	790	N	645	V	702	490
		550							880		880		735		810		530	
		645							NA	975	VA	975	NA	830	VA	910	560	
312	2,5	7,5	600	240	140	430	470	410	535	N	815	V	895	N	705	V	705	560
		640							920		1000		810		810		605	
		740							NA	1020	VA	1100	NA	910	VA	910	650	
316	3,2	7,5	600	240	140	430	470	410	535	N	835	V	895	N	705	/	/	650
		640							940		1000		810		/		695	
		740							NA	1040	VA	1100	NA	910	/	740		
525	5	6	680	305	140	485	550	440	565	N	905	V	965	N	750	V	805	780
		670							1010		1070		860		910		825	
		770							NA	1110	VA	1170	NA	960	VA	1010	910	

N - V - NA - VA = velocità di sollevamento (vedi pagina 56) / lifting speeds (see page 56)

REAZIONI ALLA SINGOLA RUOTA - SINGLE WHEEL REACTION

$$\frac{P + Pp}{4} = \text{Kg}$$

P (Portata / Capacity)
Pp (Peso paranco / Hoist weight)

Paranchi standard SERIE XM

XM SERIES standard hoists

PARANCO CON CARRELLO BITRAVE

HOIST WITH BIRAIL TROLLEY

XM 308 / 312 / 316 / 525

PARANCHI A DOPPIA USCITA

DAL TAMBURO D2 (4/2) TIRO CENTRALE

HOISTS WITH DOUBLE OUTPUT
FROM THE DRUM D2 (4/2) TRUE VERTICAL LIFT

Tipo 53 CARRELLO BITRAVE CON PARANCO APPOGGIATO
BIRAIL TROLLEY HOIST SUPPORTED

Tipo 53C1 CARRELLO BITRAVE CON PARANCO SOSPESO
BIRAIL TROLLEY HOIST SUSPENDED

XM 308 / 312 / 316 / 525

Tipo 53

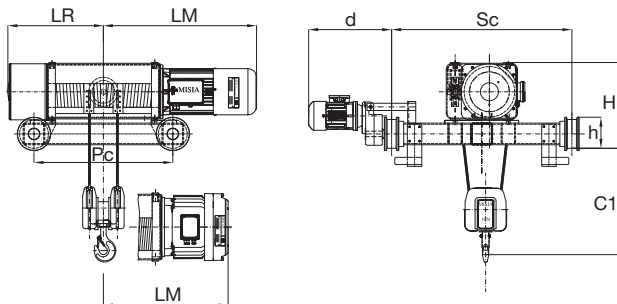

XM 308 / 312 / 316 / 525

Tipo 53C1

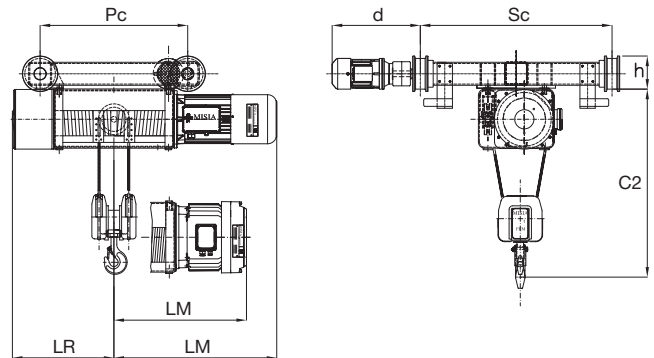

XM 308 / 312 / 316 / 525

Paranco Hoist	Portata Capacity	Corsa gancio Hook travel	Dimensioni Dimensions						Motori cilindrici Cylindrical motors				Motori conici Conical motors			Peso Weight			
			Sc mm	C1 mm	H mm	C2 mm	h mm	d mm	Pc mm	LR mm	Speed m/min	LM mm	Speed m/min	LM mm	Speed m/min		LM mm	Speed m/min	LM mm
308	1,6	6	1000	500	490	830	175	480	720	460	N	790	V	790	N	645	V	705	525
		900							550	880		880		735		810		550	
		13							1085	645	NA	975	VA	975	NA	830	VA	910	575
312	2,5	7,5	1000	540	490	870	175	480	770	535	N	815	V	895	N	645	V	705	595
		975							640	920		1000		795		810		630	
		16							1175	740	NA	1020	VA	1100	NA	830	VA	910	665
316	3,2	7,5	1000	540	490	870	175	480	770	535	N	835	V	895	N	705	/	/	685
		975							640	940		1000		810		/		720	
		16							1175	740	NA	1040	VA	1100	NA	910	/	/	765
525	5	6	1000	580	550	960	175	510	790	565	N	905	V	965	N	750	V	805	815
		995							670	1010		1070		840		910		860	
		14							1195	770	NA	1110	VA	1170	NA	960	VA	1010	905

Velocità carrello / Trolley speed: 20 - 16 - 20/6,5 - 16/5,3 m/min
N - V - N A - V A = velocità di sollevamento (vedi pagina 56) / lifting speeds (see page 56)

REAZIONI ALLA SINGOLA RUOTA - SINGLE WHEEL REACTION

$$\frac{P + P_p}{4} = \text{Kg}$$

P (Portata / Capacity)
Pp (Peso paranco / Hoist weight)

Paranchi standard SERIE XM

XM SERIES standard hoists

PARANCO CON CARRELLO BITRAVE

HOIST WITH BIRAIL TROLLEY

XM 740 / 750 / 963 / 980

PARANCHI A DOPPIA USCITA

DAL TAMBURO D2 (4/2) TIRO CENTRALE

HOISTS WITH DOUBLE OUTPUT
FROM THE DRUM D2 (4/2) TRUE VERTICAL LIFT

Tipo 53 CARRELLO BITRAVE CON PARANCO APPOGGIATO
BIRAIL TROLLEY HOIST SUPPORTED

Tipo 53C1 CARRELLO BITRAVE CON PARANCO SOSPESO
BIRAIL TROLLEY HOIST SUSPENDED

XM 740 / 750 / 963 / 980

Tipo 53

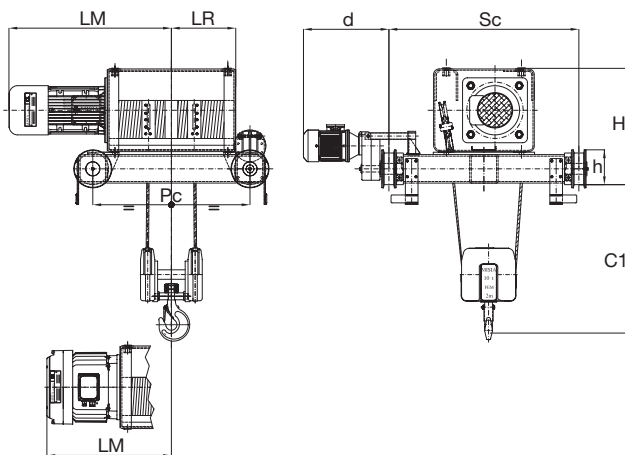

XM 740 / 750 / 963 / 980

Tipo 53C1

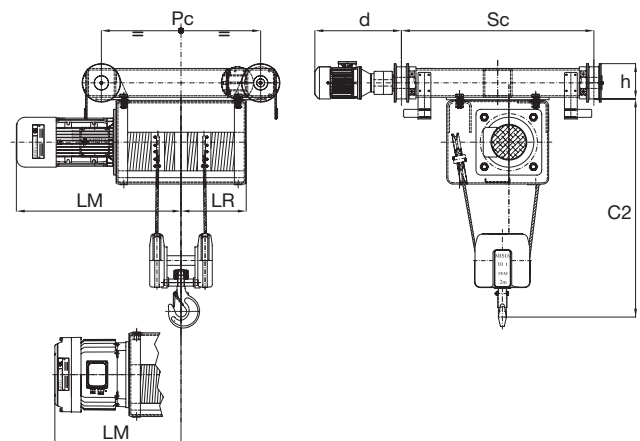

XM 740 / 750 / 950 / 963 / 980

Paranco Hoist	Portata Capacity	Corsa gancio Hook travel	Dimensioni Dimensions							Motori cilindrici Cylindrical motors				Motori conici Conical motors				Peso Weight	
			Sc mm	C1 mm	H mm	C2 mm	h mm	d mm	Pc mm	LR mm	Speed m/min	LM mm	Speed m/min	LM mm	Speed m/min	LM mm	Speed m/min		LM mm
740	8	7	1200	720	740	1260	215	540	993	405	N	1030	/	/	N	870	/	/	1270
		1108							510	1135		975				1320			
		1423							620	NA	1245	1080	1380						
750	10	7	1200	720	740	1260	215	540	993	405	N	1030	/	/	N	870	V	890	1270
		1108							510	1135		975				1320			
		1426							620	NA	1245	1080	1380						
963	10	8	1450	760	880	1400	270	630	1160	480	N	1200	V	1240	N	940	V	940	1910
		1575							690	1460		1500		1150		2090			
		2075							940	NA	1660	1700	NA	1400	VA	1400	2305		
963	12,5	8	1450	760	880	1400	270	630	1160	480	N	1200	/	/	N	940	/	/	1910
		1575							690	1460		1150				2090			
		2075							940	NA	1660	NA	1400	2305					
980	16	8	1450	760	880	1400	270	630	1160	480	N	1200	/	/	N	960	/	/	1930
		1575							690	for		1460				1170			2110
		2075							940	inverter	1660	NA	1420	2325					

Velocità carrello / Trolley speed: 20 - 16 - 20/6,5 - 16/5,3 m/min
N - V - NA - VA = velocità di sollevamento (vedi pagina 56) / lifting speeds (see page 56)

REAZIONI ALLA SINGOLA RUOTA - SINGLE WHEEL REACTION

$$\frac{P + Pp}{4} = \text{Kg}$$

P (Portata / Capacity)
Pp (Peso paranco / Hoist weight)

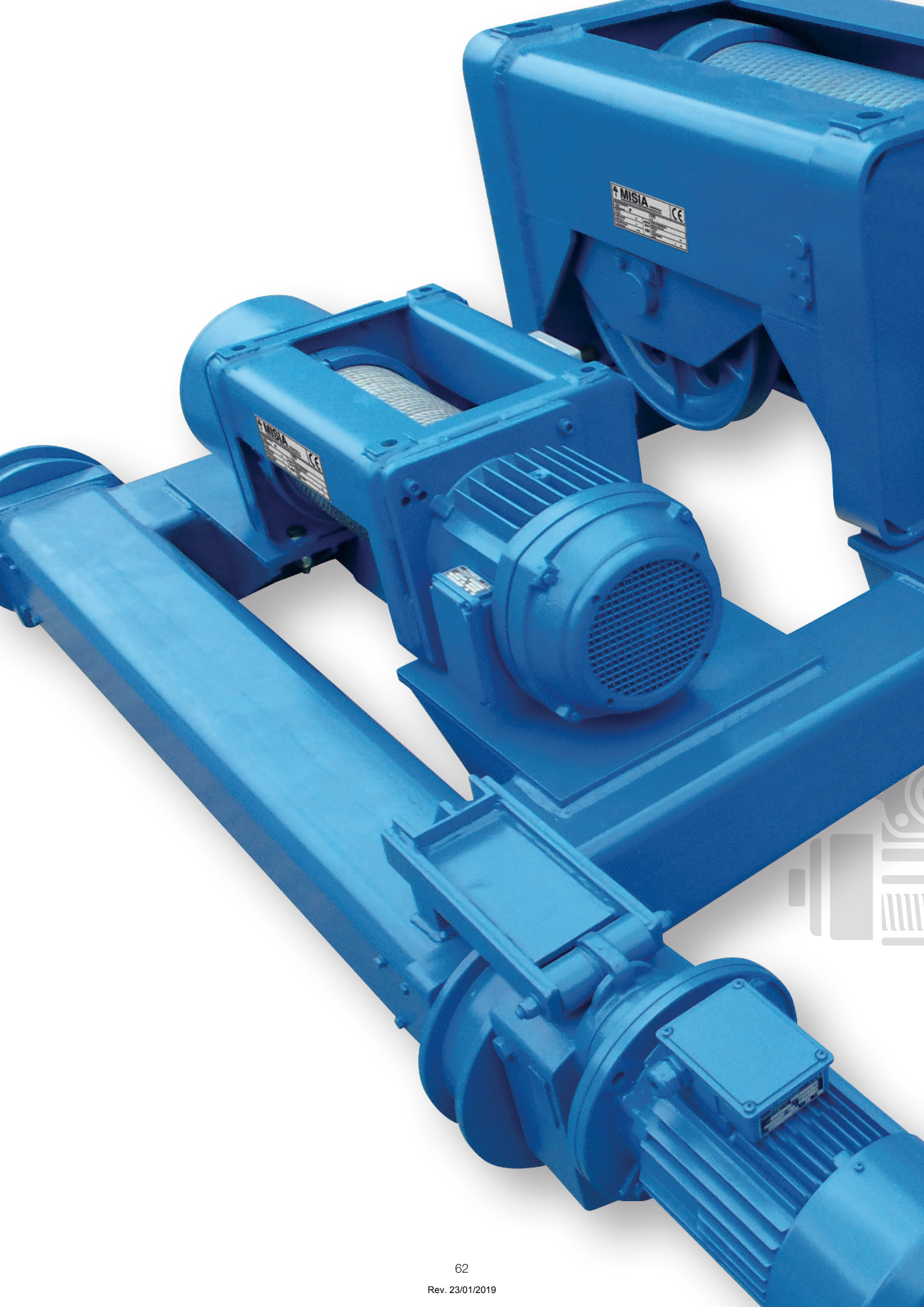

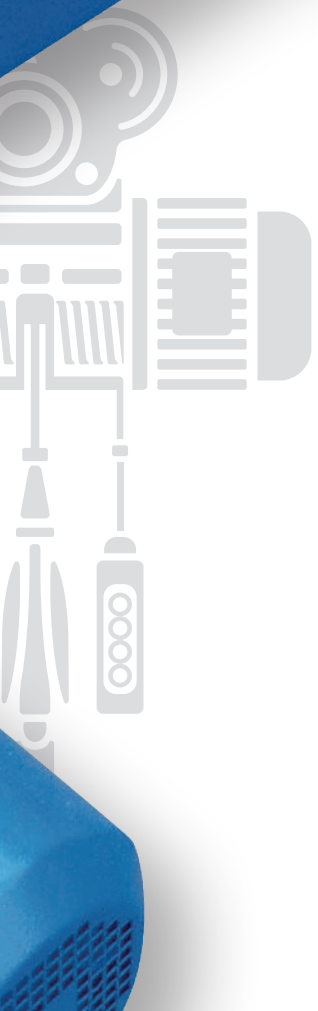
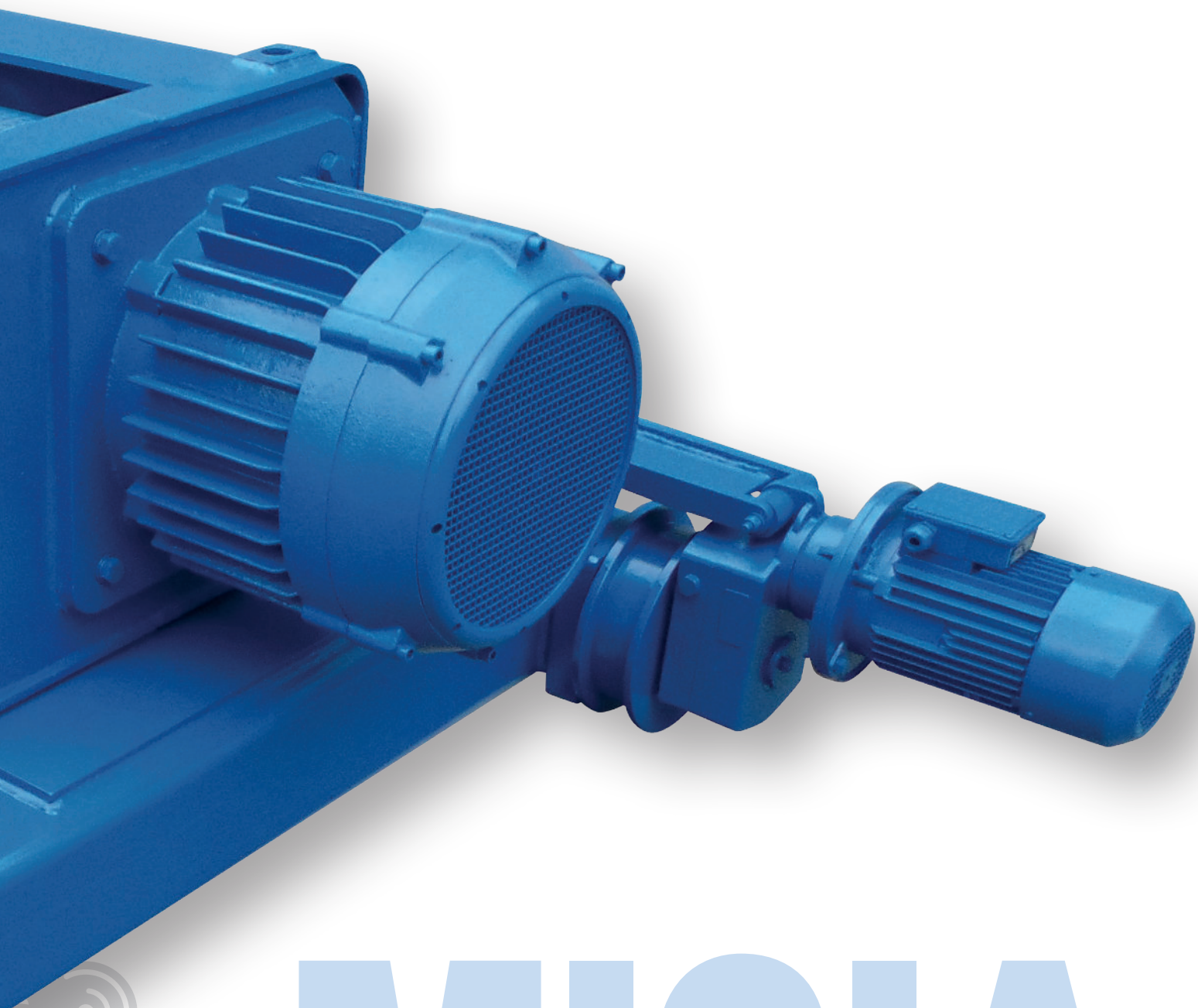

MISIA



Paranchi speciali
Special hoists

Paranchi speciali SERIE XM XM SERIES special hoists

TIPO DC2 A DOPPIA USCITA DI FUNE E SINGOLO TIRO CONTRAPPOSTO RINVIATO Paranchi a doppia uscita dal tamburo

TYPE DC2 OPPOSITE DOUBLE ROPE OUTPUT
WITH 2/2+2 ROPE FALLS
Hoists with double outlet from the drum

XM 308 / 312 / 316 / 525

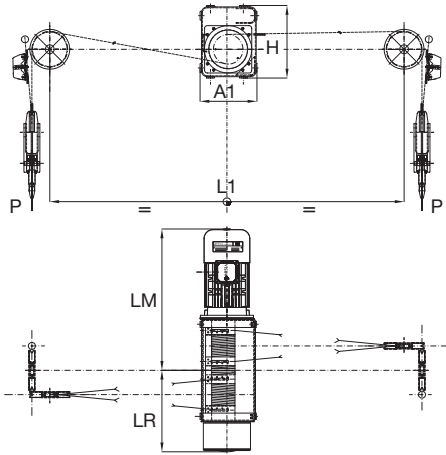

XM 740 / 750 / 963 / 980

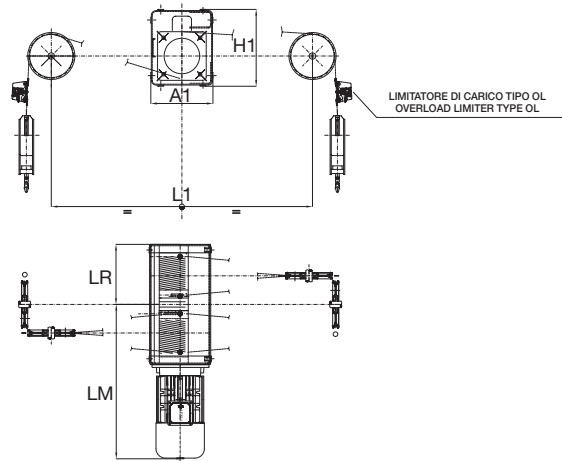

CARATTERISTICHE TECNICHE - TECHNICAL DATA

Portata max Max capacity	Gruppo Group	Paranco Hoist	Tiri fune Rope falls	Corse gancio Hook travel			Velocità sollevamento (m/min) Lifting speed (m/min)					
							1 velocità 1 speed		2 velocità 2 speed			
									Motori cilindrici Cylindrical motors		Motori conici Conical motors	
kg	FEM	XM		m	m	m	N m/min	V m/min	NA m/min	VA m/min	NA m/min	VA m/min
800+800	2 m	308 DC2	2 + 2/2	6	10	13	8	12	8/2,6	12/4	8/2,6	12/4
1250+1250	2 m	312 DC2	2 + 2/2	7,5	12	16	8	12	8/2,6	12/4	8/2,6	12/4
1600+1600	2 m	316 DC2	2 + 2/2	7,5	12	16	8	12	8/2,6	12/4	8/1,3	12/2
2500+2500	2 m	525 DC2	2 + 2/2	6	10	14	8	12	8/2,6	12/4	8/1,3	12/2
4000+4000	1 Am	740 DC2	2 + 2/2	7	11,5	16	8	12	8/2,6	/	8/1,3	/
5000+5000	1 Am	750 DC2	2 + 2/2	7	11,5	16	5	8	/	8/2,6	5/1,2	8/1,3
5000+5000	2 m	963 DC2	2 + 2/2	11	21	32,5	7,5	/	7,5/2,5	/	6/1,5	/
6300+6300	1 Am	963 DC2	2 + 2/2	11	21	32,5	7,5	/	7,5/2,5	/	5/1,2	/
8000+8000	1 Am	980 DC2	2 + 2/2	8,5	16,5	26	7,5	/	/	/	5/1,2	/

Le velocità sono riferite a una frequenza di 50 Hz / The lifting speed refer to a frequency of 50 Hz

DC2 (2/2+2) A 2+2 TIRI DI FUNE - DC2 (2/2+2) 2+2 ROPE FALLS

Paranco/Hoist	XM	308	312	316	525	740	750	963	980																	
Tipo/Type	DC2 (2/2+2)																									
Capacità/Capacity (P)	t	0,8+0,8		1,25+1,25		1,6+1,6		2,5+2,5		4+4		5+5		6,3+6,3		8+8										
Corse gancio/Hook travel	m	6	10	13	7,5	12	16	7,5	12	16	6	10	14	7	11,5	16	7	11,5	16	11	21	32	8,5	16,5	26	
H1	mm	400			400			450			640			640			730			730						
A1	mm	310			310			360			545			545			600			600						
min. L1	mm	2390	3680	4990	2520	3980	5405	2520	3980	5405	2460	3920	5350	2660	4200	5740	2660	4200	5740	3430	6400	9980	3330	6290	9870	
LR	mm	460	550	645	535	640	740	535	640	740	565	670	770	405	510	620	405	510	620	480	690	940	480	690	940	
Motori cilindrici Cylindrical motor	Vel. soll./Lift. speed	N - N A		N - N A		N - N A		N - N A		N - N A		N - N A		N - N A		N - N A		N - N A		N - N A		N - N A				
	LM	mm	790	880	975	815	920	1020	895	940	1040	905	1010	1110	1030	1135	1245	1030	1135	1245	1100	1210	1560	1180	1390	1640
	Vel. soll./Lift. speed	V - V A		V - V A		V - V A		V - V A		V - V A		V - V A		V - V A		V - V A		V - V A		V - V A		V - V A		V - V A		
Motori conici Conical motor	Vel. soll./Lift. speed	N - N A		N - N A		N - N A		N - N A		N - N A		N - N A		N - N A		N - N A		N - N A		N - N A		N - N A				
	LM	mm	645	735	830	705	810	910	705	810	910	715	820	920	870	975	1085	870	975	1085	940	1150	1400	960	1170	1420
	Vel. soll./Lift. speed	V - V A		V - V A		V - V A		V - V A		V - V A		V - V A		V - V A		V - V A		V - V A		V - V A		V - V A		V - V A		
Peso/Weight	kg	150	170	190	220	240	260	220	240	260	330	370	410	620	670	720	620	670	720	980	1130	1300	980	1130	1300	

N - V - N A - V A = velocità di sollevamento (vedi tabella sopra) / lifting speeds (see table above)

Paranchi speciali SERIE XM XM SERIES special hoists

TIPO DC1 A DOPPIA USCITA E SINGOLO TIRO CONTRAPPOSTO Paranchi a doppia uscita dal tamburo

TYPE DC1 OPPOSITE DOUBLE ROPE
OUTPUT WITH 2/1+1 ROPE FALLS
Hoists with double outlet from the drum

XM 308 / 312 / 316 / 525

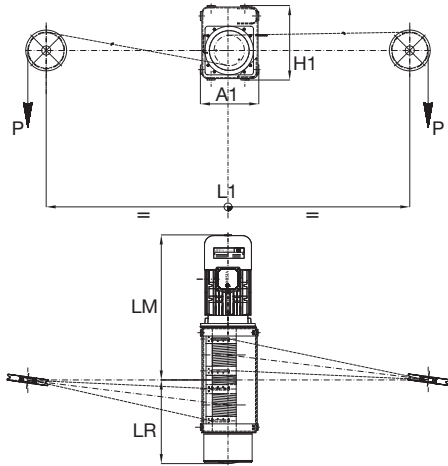

XM 740 / 750 / 963 / 980

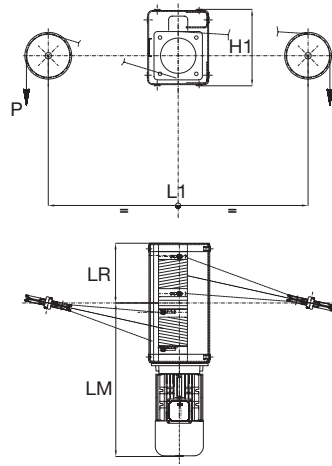

CARATTERISTICHE TECNICHE - TECHNICAL DATA

Portata max Max capacity	Gruppo Group	Paranco Hoist	Tiri fune Rope falls	Corse gancio Hook travel			Velocità sollevamento (m/min) Lifting speed (m/min)					
							1 velocità 1 speed		2 velocità 2 speed			
									Motori cilindrici Cylindrical motors		Motori conici Conical motors	
kg	FEM	XM		m	m	m	N m/min	V m/min	NA m/min	VA m/min	NA m/min	VA m/min
400+400	2 m	308 DC1	1 + 1/2	12	20	26	16	24	16/5,2	24/8	16/5,2	24/8
625+625	2 m	312 DC1	1 + 1/2	15	24	32	16	24	16/5,2	24/8	16/5,2	24/8
800+800	2 m	316 DC1	1 + 1/2	15	24	32	16	24	16/5,2	24/8	16/2,6	/
1250+1250	2 m	525 DC1	1 + 1/2	12	20	28	16	24	16/5,2	24/8	16/2,6	24/4
2000+2000	1 Am	740 DC1	1 + 1/2	14	23	32	16	24	16/5,2	/	16/2,6	/
2500+2500	1 Am	750 DC1	1 + 1/2	14	23	32	10	16	/	16/5,2	10/2,5	/
2500+2500	2 m	963 DC1	1 + 1/2	22	42	65	15	/	15/5	/	12/3	/
3150+3150	1 Am	963 DC1	1 + 1/2	22	42	65	15	/	15/5	/	10/2,5	/
4000+4000	1 Am	980 DC1	1 + 1/2	17	33	52	15	/	/	/	10/2,5	/

Le velocità sono riferite a una frequenza di 50 Hz / The lifting speed refer to a frequency of 50 Hz

DC1 (2/1+1) A 1+1 TIRI DI FUNE - DC1 (2/1+1) 1+1 ROPE FALLS

Paranco/Hoist	XM	308	312	316	525	740	750	963	980																	
Tipo/Type	DC1 (2/1+1)																									
Capacità/Capacity (P)	t	0,4+0,4		0,625+0,625		0,8+0,8		1,25+1,25		2+2		2,5+2,5		3,15+3,15		4+4										
Corse gancio/Hook travel	m	12	20	26	15	24	32	15	24	32	12	20	28	14	23	32	/	/	/	/	/	/				
H1	mm	400			400			450			640			640			730			730						
A1	mm	310		310		310		360		545		545		600		600										
min. L2	mm	2400	3700	5000	2550	4000	5450	2550	4000	5450	2500	3950	5400	2700	4250	5800	2700	4250	5800	3450	6450	10000	3400	6300	9900	
LR	mm	460	550	645	535	640	740	535	640	740	565	670	770	405	510	620	405	510	620	480	690	940	480	690	940	
Motori cilindrici Cylindrical motor	Vel. soll./Lift. speed	N - N A		N - N A		N - N A		N - N A		N - N A		N - N A		N - N A		N - N A		N - N A		N - N A						
	LM	mm	790	880	975	815	920	1020	835	940	1040	905	1010	1110	1030	1135	1245	1030	1135	1245	1100	1210	1560	1180	1390	1640
	Vel. soll./Lift. speed	V - V A		V - V A		V - V A		V - V A		V - V A		V - V A		V - V A		V - V A		V - V A		V - V A		V - V A				
LM	mm	790	880	975	895	1000	1100	895	1000	1100	965	1070	1170	/	/	/	/	/	/	/	/	/	/	/	/	/
Motori conici Conical motor	Vel. soll./Lift. speed	N - N A		N - N A		N - N A		N - N A		N - N A		N - N A		N - N A		N - N A		N - N A		N - N A						
	LM	mm	590	680	775	665	770	870	705	810	910	715	820	920	870	975	1085	870	975	1085	940	1150	1400	960	1170	1420
	Vel. soll./Lift. speed	V - V A		V - V A		V - V A		V - V A		V - V A		V - V A		V - V A		V - V A		V - V A		V - V A		V - V A				
LM	mm	640	730	825	705	810	910	/	/	/	805	910	1010	/	/	/	890	995	1105	/	/	/	/	/	/	
Peso/Weight	kg	150	170	190	220	240	260	220	240	260	330	370	410	620	670	720	620	670	720	980	1130	1300	980	1130	1300	

N - V - N A - V A = velocità di sollevamento (vedi tabella sopra) / lifting speeds (see table above)

Paranchi speciali 6/1 6/1 special hoists

PARANCHI SPECIALI A SINGOLA USCITA FUNE DAL TAMBURO 6/1

SPECIAL HOIST WITH SINGLE OUTPUT
FROM THE DRUM 6/1

SR6 A 6 TIRI DI FUNE (6/1) - 6 ROPE FALLS (6/1)

Tipo 5 PARANCO APPOGGIATO - SUPPORTED HOIST

Tipo 53 CARRELLO PARANCO BIROTAIA
HOIST TROLLEY BIRAIL

SR6

Tipo 5

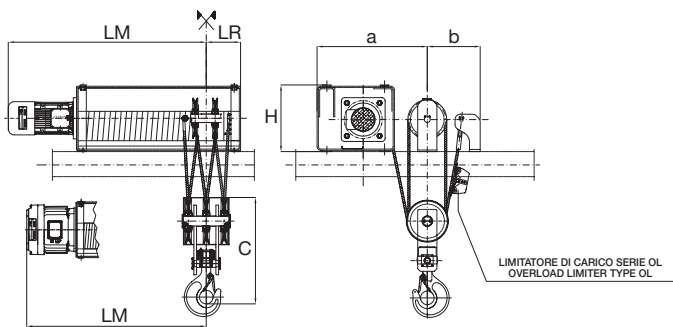

SR6

Tipo 53

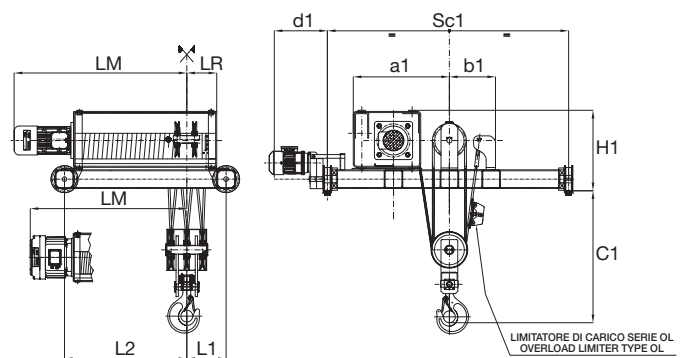

SR6 - A 6 TIRI DI FUNE (6/1) - SR6 - 6 ROPE FALLS (6/1)

Paranco/Hoist		XM	740			750			963			963			980		
Portata/Capacity		kg	24000			30000			30000			37500			48000		
Gruppo/Group		FEM	1Am			1Am			2m			1Am			1Am		
Corsa gancio/Hook travel		m	6,5	11	15	6,5	11	15	6,5	10,5	16	6,5	10,5	16	6,5	10,5	16
Motori cilindrici Cylindrical motor	Vel. soll./Lift. speed	m/min	2,7			2,7			2,5			3			2,5		
	Pot. mot./Mot. power	kW	12			15			15			24			24		
	Vel. soll./Lift. speed	m/min	2,7/0,9			2,7/0,9			2,5/0,8			2,5/0,8			-		
	Pot. mot./Mot. power	kW	12/4			15/5			16/5,3			22/7,3			-		
Motori conici Conical motor	Vel. soll./Lift. speed	m/min	2,7			2,7			2			1,7			1,7		
	Pot. mot./Mot. power	kW	12,5			15			12,5			12,5			16		
	Vel. soll./Lift. speed	m/min	2,7/0,3			2,7/0,5			2/0,5			1,7/0,4			1,7/0,4		
	Pot. mot./Mot. power	kW	13/3			15/2,5			13/3			13/3			16/4		
Fig 5	H	mm	530			530			625			625			625		
	C	mm	900			1000			1100			1100			1240		
	a	mm	840			840			990			990			990		
	b	mm	380			380			480			480			480		
	LR	mm	250			257			277			288			189		
Motori cilindrici/Cylindrical motor	LM	mm	1175	1605	1995	1165	1595	1985	1305	1720	2220	1370	1790	2290	/	/	/
Motori conici/Conical motor	LM	mm	1065	1495	1885	1065	1495	1885	1125	1540	2040	1190	1610	2110	1290	1710	2210
Peso/Weight		≈ kg	900	1000	1080	980	1080	1160	1480	1630	1810	1480	1630	1810	1610	1760	1940
Fig 53	Sc1	mm	2000			2000			2500			2500			2500		
	H1	mm	790			790			900			900			940		
	C1	mm	1100			1200			1300			1300			1450		
	d1	mm	570			570			570			570			570		
	a	mm	840			840			990			990			990		
	b	mm	380			380			480			480			480		
	L1	mm	420			430			460			520			450		
	L2	mm	670	1100	1500	680	1110	1510	800	1210	1710	850	1260	1760	950	1360	1860
Motori cilindrici/Cylindrical motor	LM	mm	1175	1605	1995	1165	1595	1985	1305	1720	2220	1370	1790	2290	/	/	/
Motori conici/Conical motor	LM	mm	1065	1495	1885	1065	1495	1885	1125	1540	2040	1190	1610	2110	1290	1710	2210
Peso/Weight		≈ kg	1750	1900	2030	2030	2230	2410	2470	2720	3000	3170	3420	3700	3690	3940	4220

Velocità carrello / Trolley speed: 16 - 16/5,3 m/min

Paranchi speciali 8/1 8/1 special hoists

PARANCHI SPECIALI A SINGOLA USCITA FUNE DAL TAMBURO 8/1

SPECIAL HOIST WITH SINGLE OUTPUT
FROM THE DRUM 8/1

SR8 A 8 TIRI DI FUNE (8/1) - 8 ROPE FALLS (8/1)

Tipo 5 PARANCO APPOGGIATO - SUPPORTED HOIST

Tipo 53 CARRELLO PARANCO BIROTAIA
HOIST TROLLEY BIRAIL

SR8

Tipo 5

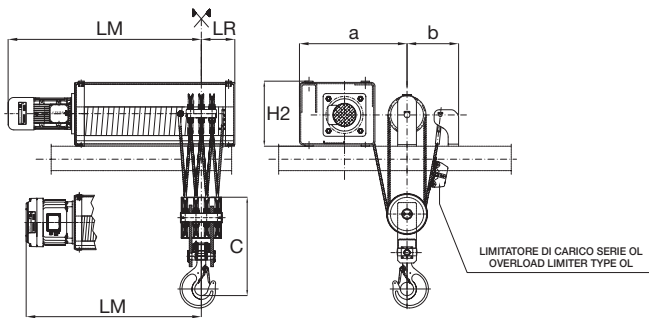

SR8

Tipo 53

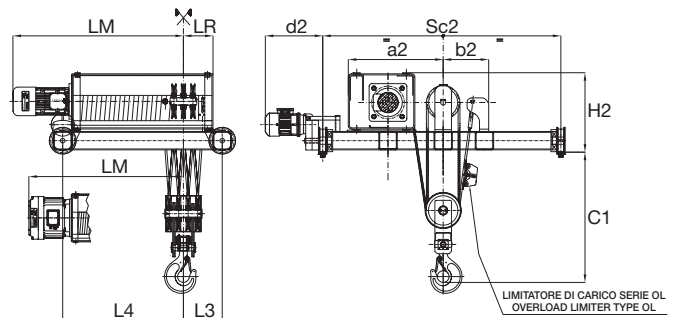

SR8 - A 8 TIRI DI FUNE (8/1) - SR8 - 8 ROPE FALLS (8/1)

Paranco/Hoist		XM	740			750			963			963			980		
Portata/Capacity		kg	32000			40000			40000			50000			64000		
Gruppo/Group		FEM	1Am			1Am			2m			1Am			1Am		
Corsa gancio/Hook travel		m	4,5	8	11	4,5	8	11	5	8	12	5	8	12	5	8	12
Motori cilindrici Cylindrical motor	Vel. soll./Lift. speed	m/min	2			2			3			2,5			2		
	Pot. mot./Mot. power	kW	12			15			24			24			24		
	Vel. soll./Lift. speed	m/min	2/0,7			2/0,7			2/0,7			2/0,7			-		
	Pot. mot./Mot. power	kW	12/4			15/5			16/5,3			22/7,3			-		
Motori conici Conical motor	Vel. soll./Lift. speed	m/min	2			2			1,5			1,2			1,2		
	Pot. mot./Mot. power	kW	12,5			15			12,5			12,5			16		
	Vel. soll./Lift. speed	m/min	2/0,5			2/0,3			1,5/0,4			1,2/0,3			1,2/0,3		
	Pot. mot./Mot. power	kW	13/3			15/2,5			13/3			13/3			16/4		
Fig 5	H	mm	530			530			625			625			625		
	C	mm	950			1080			1160			1160			1200		
	a	mm	840			840			990			990			990		
	b	mm	380			380			480			480			480		
	LR	mm	250			257			277			288			295		
Motori cilindrici/Cylindrical motor	LM	mm	1175	1605	1995	1165	1595	1985	1305	1720	2220	1370	1790	2290	/	/	/
Motori conici/Conical motor	LM	mm	1065	1495	1885	1065	1495	1885	1125	1540	2040	1190	1610	2110	1185	1605	2105
Peso/Weight		≈ kg	990	1090	1170	1110	1210	1190	1600	1750	1930	1600	1750	1930	1740	1890	2070
Fig 53	Sc2	mm	2000			2000			2500			2500			2500		
	H2	mm	790			790			900			940			960		
	C1	mm	1150			1250			1350			1350			1500		
	d2	mm	570			570			570			570			570		
	a2	mm	840			840			990			990			990		
	b2	mm	380			380			480			480			480		
	L3	mm	430			490			520			520			600		
	L4	mm	680	1110	1510	730	1160	1560	860	1270	1770	850	1260	1760	900	1310	1810
LR	mm	250			257			277			288			295			
Motori cilindrici/Cylindrical motor	LM	mm	1175	1605	1995	1165	1595	1985	1305	1720	2220	1370	1790	2290	/	/	/
Motori conici/Conical motor	LM	mm	1065	1495	1885	1065	1495	1885	1125	1540	2040	1190	1610	2110	1185	1605	2105
Peso/Weight		≈ kg	2030	2230	2410	2840	3040	3220	3290	3540	3820	3290	3540	3820	3760	4010	4290

Velocità carrello / Trolley speed: 16 - 16/5,3 m/min



MISIA



Corse gancio lunghe
High lifting height



Paranchi speciali SERIE XML XML SERIES special hoists

PARANCO A PIEDINI FOOT MOUNTED HOIST

PARANCI SPECIALI S2 - A 2 TIRI DI FUNE (2/1) CORSE GANCIO LUNGHE

SPECIAL HOIST S2 - 2 ROPE FALLS (2/1)
HIGH LIFTING HEIGHT

Tipo 5 APPOGGIATO - SUPPORTED

Tipo 5C1 SOSPESO - SUSPENDED



Tipo 5 / Tipo 5C1

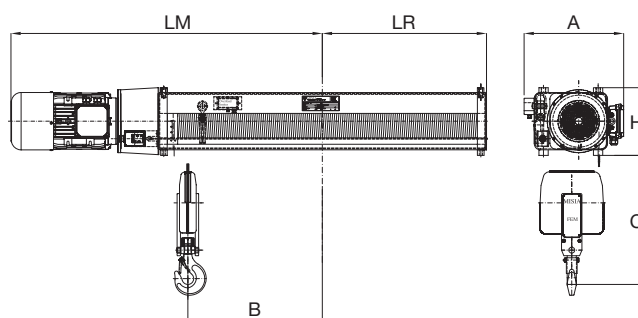

CARATTERISTICHE TECNICHE PARANCI SERIE XML - TECHNICAL DATA HOISTS XML SERIES

Portata max Max capacity	Gruppo Group	Paranco Hoist	Tiri fune Rope falls	Corse gancio Hook travel				Velocità sollevamento - Potenza motore Lifting speed - Motor power					
								N		V		VA	
				kg	FEM	XML	m	m	m	m	m/min	kW	m/min
1600	2 m	308	2/1	46	57	68	79	8	2,5	12	4	12/4	4/1,3
2500	2 m	312	2/1	32	40	48	56	8	4	12	6	12/4	6/2
3200	2 m	316	2/1	32	40	48	56	8	5	12	7	12/4	7/2,3
5000	2 m	525	2/1	32	40	48	56	8	8	12	12	12/4	12/4

5 - APPOGGIATO / 5C1 - SOSPESO - 5 - SUPPORTED / 5C1 - SUSPENDED

Paranco Hoist	Portata Capacity	Corsa gancio Hook travel	Dimensioni Dimensions					Motori cilindrici Cylindrical motors				Peso Weight		
			C mm	H mm	A mm	LR mm	B mm	Speed m/min	LM mm	Speed m/min	LM mm			
308	1,6	46	570	370	450	625	459	N	1260	V	1260	320		
						760	594						1400	1400
						890	727						1530	1530
						1025	862						NA	1660
312	2,5	32	640	370	450	625	459	N	1260	V	1330	330		
						760	594						1400	1470
						890	727						1530	1600
						1025	862						NA	1660
316	3,2	40	640	370	450	625	459	N	1300	V	1330	330		
						760	594						1440	1470
						890	727						1570	1600
						1025	862						NA	1700
525	5	32	730	440	510	640	445	N	1400	V	1450	410		
						775	580						1530	1580
						910	715						1665	1715
						1045	850						NA	1800

N - V - N A - V A = velocità di sollevamento (vedi tabella sopra) / lifting speeds (see table above)



Paranchi speciali SERIE XML XML SERIES special hoists

PARANCO CON CARRELLO MONOTRAVE HOIST WITH MONORAIL TROLLEY

PARANCI SPECIALI S2 - A 2 TIRI DI FUNE (2/1) CORSE GANCIO LUNGHE SPECIAL HOIST S2 - 2 ROPE FALLS (2/1) HIGH LIFTING HEIGHT

Tipo 3 CARRELLO MONOTRAVE A INGOMBRO NORMALE STANDARD HEADROOM TROLLEY

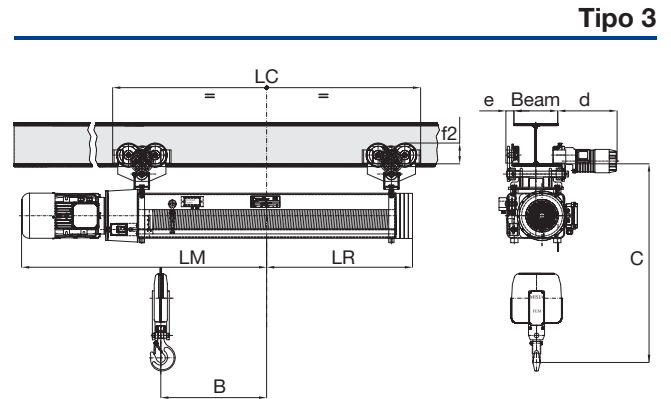

CARATTERISTICHE TECNICHE PARANCI SERIE XML - TECHNICAL DATA HOISTS XML SERIES

Portata max Max capacity	Gruppo Group	Paranco Hoist	Tiri fune Rope falls	Corse gancio Hook travel				Velocità sollevamento - Potenza motore Lifting speed - Motor power					
				m	m	m	m	N		V		VA	
								m/min	kW	m/min	kW	m/min	kW
1600	2 m	308	2/1	46	57	68	79	8	2,5	12	4	12/4	4/1,3
2500	2 m	312	2/1	32	40	48	56	8	4	12	6	12/4	6/2
3200	2 m	316	2/1	32	40	48	56	8	5	12	7	12/4	7/2,3
5000	2 m	525	2/1	32	40	48	56	8	8	12	12	12/4	12/4

3 - CARRELLO A INGOMBRO NORMALE - 3 - STANDARD HEADROOM TROLLEY

Paranco Hoist	Portata Capacity	Corsa gancio Hook travel	Dimensioni Dimensions							Motori cilindrici Cylindrical motors				Peso Weight
			C mm	d mm	e mm	LC mm	LR mm	B mm	f2 mm	Speed m/min	LM mm	Speed m/min	LM mm	
308	1,6	46	1070	410	55	1580	800	459	145	N	1260	V	1260	520
						1850	940	594			1400		1400	
						2115	1070	727			1530		1530	
						2385	1200	862			1660		1660	
312	2,5	32	1140	410	55	1580	800	459	145	N	1260	V	1330	530
						1850	940	594			1400		1470	
						2115	1070	727			1530		1600	
						2385	1200	862			1660		1730	
316	3,2	40	1140	410	55	1580	800	459	145	N	1300	V	1330	530
						1850	940	594			1440		1470	
						2115	1070	727			1570		1600	
						2385	1200	862			1700		1730	
525	5	32	1270	430	70	1660	825	445	165	N	1400	V	1450	670
						1930	960	580			1530		1580	
						2200	1100	715			1665		1715	
						2470	1230	850			1800		1850	

Velocità carrello / Trolley speed: 18 - 18/6 m/min

N - V - N A - V A = velocità di sollevamento (vedi tabella sopra) / lifting speeds (see table above)

Paranchi speciali SERIE XML XML SERIES special hoists

PARANCO CON CARRELLO BITRAVE HOIST WITH BIRAIL TROLLEY

PARANCI SPECIALI S2 - A 2 TIRI DI FUNE (2/1) CORSE GANCIO LUNGHE SPECIAL HOIST S2 - 2 ROPE FALLS (2/1) HIGH LIFTING HEIGHT

Tipo 53 CARRELLO BITRAVE CON PARANCO APOGGIATO
BIRAIL TROLLEY HOIST SUPPORTED

Tipo 53C1 CARRELLO BITRAVE CON PARANCO SOSPESO
BIRAIL TROLLEY HOIST SUSPENDED

Tipo 53

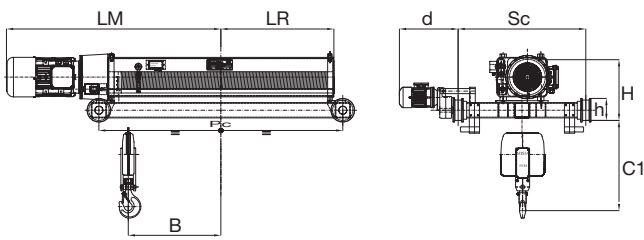

Tipo 53C1

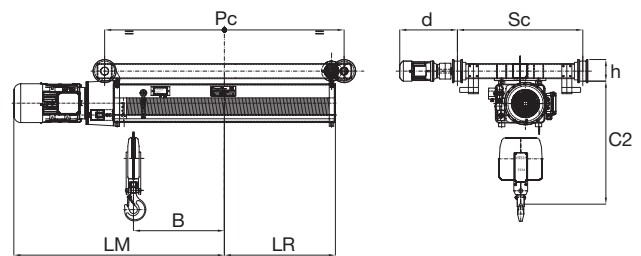

CARATTERISTICHE TECNICHE PARANCI SERIE XML - TECHNICAL DATA HOISTS XML SERIES

Portata max Max capacity	Gruppo Group	Paranco Hoist	Tiri fune Rope falls	Corse gancio Hook travel				Velocità sollevamento - Potenza motore Lifting speed - Motor power					
				m	m	m	m	N		V		VA	
								m/min	kW	m/min	kW	m/min	kW
1600	2 m	308	2/1	46	57	68	79	8	2,5	12	4	12/4	4/1,3
2500	2 m	312	2/1	32	40	48	56	8	4	12	6	12/4	6/2
3200	2 m	316	2/1	32	40	48	56	8	5	12	7	12/4	7/2,3
5000	2 m	525	2/1	32	40	48	56	8	8	12	12	12/4	12/4

53-53C1 - CARRELLO BITRAVE - 53-53C1 - BIRAIL TROLLEY

Paranco Hoist	Portata Capacity	Corsa gancio Hook travel	Dimensioni Dimensions											Motori cilindrici Cylindrical motors				Peso Weight
			Sc mm	C1 mm	H mm	C2 mm	h mm	d mm	Pc mm	B mm	Lr mm	f2 mm	Speed m/min	LM mm	Speed m/min	LM mm	Kg	
308	1,6	46	1000	570	490	900	175	480	1375	459	625	145	N	1260	V	1260	550	
		1645							594	760	1400			1400				
		1910							727	890	1530			1530				
		2180							862	1025	1660			1660				
312	2,5	32	1000	640	490	965	175	480	1375	459	625	145	N	1260	V	1330	560	
		1645							594	760	1400			1470				
		1910							727	890	1530			1600				
		2180							862	1025	1660			1730				
316	3,2	32	1000	640	490	965	175	480	1375	459	625	145	N	1300	V	1330	590	
		1645							594	760	1440			1470				
		1910							727	890	1570			1600				
		2180							862	1025	1700			1730				
525	5	32	1000	730	550	1110	175	480	1400	445	640	165	N	1400	V	1450	650	
		1670							580	775	1530			1580				
		1940							715	910	1665			1715				
		2210							850	1045	1800			1850				

N - V - N A - V A = velocità di sollevamento (vedi tabella sopra) / lifting speeds (see table above)